



---

## **Fire Management Plan**

Proposed Subdivision: Lot 9002 Larsen Road, Byford, Western Australia, 6122

Prepared for: **Goldtune Investments Pty Ltd**

RUIC Fire — PO Box 1931 Margaret River WA 6285

T: 1300797607 E: [admin@ruic.net.au](mailto:admin@ruic.net.au)



## **Fire Management Plan**

RUIC is a trading name of  
Rural Fire Risk Consultancy Pty Ltd  
PO Box 1931 Margaret River WA 6285  
ABN: 48 151 451 713



## Disclaimer and Limitation

This report is prepared solely for Goldtune Investments Pty Ltd and is not for the benefit of any other person and may not be relied upon by any other person.

The mitigation strategies contained in this Fire Management Plan are considered to be prudent minimum standards only, based on the writer's experience as well as standards prescribed by relevant authorities. It is expressly stated that RUIC and the writer do not guarantee that if such standards are complied with or if a property owner exercises prudence, that a building or property will not be damaged or that lives will not be lost in a bush fire.

Fire is an extremely unpredictable force of nature. Changing climatic factors (whether predictable or otherwise) either before or at the time of a fire can also significantly affect the nature of a fire and in a bushfire prone area it is not possible to completely guard against bushfire.

Further, the growth, planting or removal of vegetation; poor maintenance of any fire prevention measures; addition of structures not included in this report; or other activity can and will change the bushfire threat to all properties detailed in the report. Further, the achievement of the level of implementation of fire precautions will depend on the actions of the landowner or occupiers of the land, over which RUIC has no control. If the client becomes concerned about changing factors then a new Fire Risk Management Plan should be requested.

To the maximum extent permitted by the law, RUIC, its employees, officers, agents and the writer ("RUIC") excludes all liability whatsoever for:

1. claim, damage, loss or injury to any property and any person caused by fire or as a result of fire or indeed howsoever caused;
2. errors or omissions in this report except where grossly negligent; and

the client expressly acknowledges that they have been made aware of this exclusion and that such exclusion of liability is reasonable in all the circumstances.

If despite the provisions of the above disclaimer RUIC is found liable then RUIC limits its liability to the lesser of the maximum extent permitted by the law and the proceeds paid out by RUIC's professional or public liability insurance following the making of a successful claim against such insurer.

RUIC accepts no liability or responsibility whatsoever for or in respect of any use or reliance upon this report and its supporting material by any third party.

This report is valid for a period of five years only from the date of its issue.



### Document Details

ITEM	DETAIL
Project Name	Marri Park (Stage 6)
Project Number	201323
Prepared by	Greg Penney
Review by	Darrel Krammer
Approved by	 Greg Penney Director   RUIC Fire
Version	1.0
Date of Issue	20 <sup>th</sup> February 2014



## Executive Summary

---

Rural Fire Risk Consultancy Pty Ltd trading as RUIC Fire specialises in bushfire engineering and performance based design and construction solutions. RUIC Fire was engaged by the client to prepare this Fire Management Plan to support the subdivision of Lot 9002 Larsen Road, Byford, and to meet the Western Australian Planning Commission (WAPC) subdivision approval conditions for;

- Application Number: 147425, condition 19 (stages 4 & 5), and
- Application Number: 148270, condition 18 (stage 6).

Strategic assessment of the site and surrounding area was completed in accordance with Planning for Bushfire Protection Guidelines 2<sup>nd</sup> Edition (FESA, 2010) and the Rural Urban Threat Analysis Tool (FESA, 2003). Detailed site analysis was completed in accordance with methodologies utilised in AS3959:2009 Construction of buildings in bushfire prone areas; and ISO31000 Risk assessment principles and guidelines. It is concluded the bushfire hazard level of the site is not prohibitive to development.

Design bushfire was quantified and impact of such fire behaviour was modelled in accordance with established bushfire engineering principles. Design of the building protection zones and defensible spaces within the site using the design bushfire analysis results in the design exceeding the required standards defined in AS3959:2009 and Planning for Bushfire Protection Guidelines 2<sup>nd</sup> Edition (FESA, 2010), and Shire of Serpentine Jarrahdale Local Planning Policy No.43, Hazards and Natural Disasters.

The proposed subdivision was assessed against the criteria of Planning for Bushfire Protection Guidelines 2<sup>nd</sup> Edition (FESA, 2010) and documented Local Planning Policy No.43 of the Shire of Serpentine Jarrahdale. In complying with the design specifications of this Fire Management Plan, the subdivision of 9002 Larsen Road, Byford is found to be compliant with State Planning Policy 3.4 Natural Hazards; the guidance document Planning for Bushfire Protection Guidelines 2<sup>nd</sup> Edition (FESA, 2010); and documented Local Planning Policy No.43 of the Shire of Serpentine Jarrahdale.

The subdivision consists of the following residential lot allocations; 27 lots for stage 4, 33 lots for Stage 6 and quantity to be confirmed for Grouped Housing subdivision stage 5.



## Contents Page

---

<b>1.0 Introduction.....</b>	<b>8</b>
1.1 Report Description .....	8
1.1.1 Purpose of the Report.....	8
1.1.2 The Project Team.....	8
1.1.3 Assessment Methodology .....	8
<b>2.0 Site Details .....</b>	<b>9</b>
2.1 Description .....	9
2.1.1 Location .....	9
2.1.2 Area & Current Land Use .....	9
2.1.3 Proposed Land Use .....	9
2.1.4 Bushfire Zone Designation .....	9
2.1.5 Bushfire History.....	11
2.1.6 Strategic Bushfire Hazard Assessment.....	11
2.1.7 Threat Analysis using the Rural Urban Threat Analysis Tool .....	13
2.1.8 Conclusion .....	13
<b>3.0 Design Bushfire .....</b>	<b>15</b>
3.1 Introduction .....	15
3.1.1 Bushfire Weather .....	15
3.1.2 Site Topography.....	16
3.1.3 Bushfire Fuel Structure & Load .....	16
3.2 Design Bushfire Heat Flux & BAL .....	19
3.3 Conclusion .....	19
<b>4.0 Bush Fire Risk Mitigation.....</b>	<b>20</b>
4.1 Element 1 - Location of Development .....	20
4.2 Element 2 - Vehicular Access .....	21
4.3 Element 3 – Water Supply .....	23
4.4 Element 4 – Siting of Development.....	24



4.5	Element 5 – Design of Development.....	26
4.6	Element 6 – Additional Provisions.....	26
4.7	Works and Responsibilities .....	27
<b>5.0</b>	<b>Compliance Checklist for Performance Criteria and Acceptable Solutions .....</b>	<b>28</b>
5.1	Bushfire hazard levels and performance criteria .....	28
5.2	Performance Criteria and Compliance .....	28
5.3	Conclusion .....	29
<b>6.0</b>	<b>References .....</b>	<b>30</b>
<b>7.0</b>	<b>Appendix 1 – Strategic Vegetation Hazard Assessment.....</b>	<b>31</b>
<b>8.0</b>	<b>Appendix 2 – Bushfire Weather .....</b>	<b>32</b>
<b>9.0</b>	<b>Appendix 3 – Site Topography.....</b>	<b>35</b>
<b>10.0</b>	<b>Appendix 4 – Abbreviations &amp; Terms .....</b>	<b>36</b>
10.1	Abbreviations Used in the Fire Management Plan .....	36
10.2	Terminology Used in the Fire Management Plan .....	36



## 1.0 Introduction

---

### 1.1 Report Description

#### 1.1.1 Purpose of the Report

Goldtune Investments Pty Ltd (the client) engaged Rural Urban Interface Consultancy Pty Ltd (RUIC Fire) to prepare a Fire Management Plan (FMP) to support the subdivision of Lot 9002 Larsen Road, Byford (the site), to meet the conditions of the WAPC Applications, No. 147425 (condition 19), and 148270 (condition 18).

The purpose of this Fire Management Plan (FMP) is to analyse the bush fire risk and threat level of the proposed subdivision and to detail the mitigation strategies and requirements to be implemented to comply with Planning for Bushfire Protection Guidelines 2<sup>nd</sup> Edition (FESA, 2010) and all other regulatory requirements. The aim of the FMP is to reduce the occurrence and minimise the impact of bush fires thereby reducing the risk to life, property and the environment in the case of bush fire within or near the proposed development.

#### 1.1.2 The Project Team

RUIC Fire employs a team specialising in bushfire engineering and performance based designed solutions. Director Greg Penney *GIFireE, MRIA, Graduate Diploma in Bushfire Protection, BSc* is the principal consultant for the project and is the principle point of contact for all enquiries relating to the Fire Management Plan. Greg holds graduate membership with the Institute of Fire Engineers; graduated *dux* of the Fire & Rescue Station Officer School; is a member of the International Golden Key Honour Society for academic excellence; and is currently completing his Master's thesis on Risk Management within the Fire & Rescue Service in addition to postgraduate studies in Fire Safety Engineering. He currently provides education on bushfire resilient design and construction to the Master Builders Association; Australian Institute of Building Surveyors; Australian Institute of Architects and has been engaged to lecture on Planning for Bushfire Protection at the Planning Institute of Australia's Regional Conference in 2014. All other RUIC bushfire consultants who have worked on the project have completed postgraduate studies in Bushfire Protection.

#### 1.1.3 Assessment Methodology

Strategic assessment of bushfire threat at the proposed development site is in accordance with current West Australian Planning Commission requirements utilising Planning for Bushfire Protection Guidelines 2<sup>nd</sup> Edition and the Rural Urban Interface Bushfire Threat Analysis. A comprehensive and detailed site bushfire threat analysis has also been undertaken during inspection of the site utilising FESA's Visual Fuel Load Guide (2012); the Overall Fuel Hazard Assessment Guide 2<sup>nd</sup> Edition (DENR, 2012); and AS3959:2009.





## 2.0 Site Details

### 2.1 Description

#### 2.1.1 Location

The site is located in the Municipality of the Shire of Serpentine Jarrahdale, approximately 25km east south east of the Perth CBD, in the suburb of Byford (Figure 2A).



Figure 2A: Site Location

#### 2.1.2 Area & Current Land Use

The site is approximately 6.65 hectares in area. The land is currently undergoing urban development. The site is zoned “Urban Development” (Shire of Serpentine Jarrahdale, *Town Planning Scheme No 2*, 1989; as amended).

#### 2.1.3 Proposed Land Use

The proposed land use is for residential housing, abutting an existing residential development. This Fire Management Plan demonstrates the suitability of the site for Urban Development, as per the Precalculation Plan (Figure 2B).

#### 2.1.4 Bushfire Zone Designation

The Shire of Serpentine Jarrahdale uses the Planning for Bushfire Protection Guidelines, 2<sup>nd</sup> Edition, Appendix 1 methodology for determining the bushfire hazard level, as conducted by FESA. The shire does not currently have designated “Bushfire Prone Areas” throughout the municipality. Should the site be designated a bushfire prone area all dwellings within 100m of a bushfire hazard must comply with construction requirements detailed in Australian Standard AS3959 “Construction of Buildings in Bushfire Prone Areas.”



Lots affected by the Fire Management Plan will have Notifications on Title highlighting obligations and responsibilities of the landowner under the Fire Management Plan.

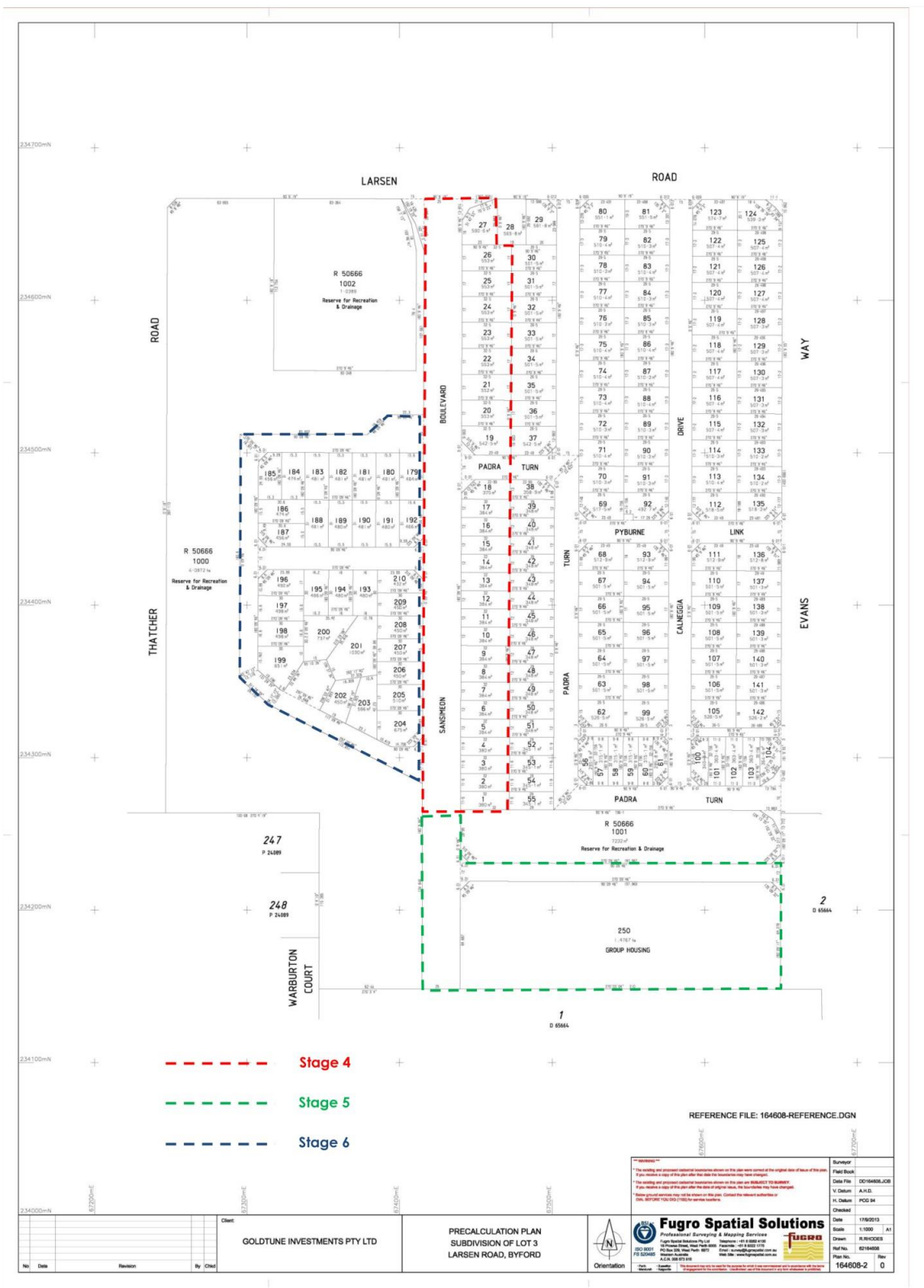

Figure 2B: Indicative development (Client, 2013)



## 2.1.5 Bushfire History

### 2.1.5.1 Gazetted Fire District

Technical and Background Paper No.27 “Western Australia” of the Australian Institute of Criminology (Bryant, 2008) provides the following analysis of historical vegetation fire response in gazetted fire districts within Western Australia:

- Between 2000-2001 to 2006-2007 the Fire and Emergency Services Authority (now the Department of Fire and Emergency Services) attended a total of 61,446 vegetation fires throughout gazetted fire districts in Western Australia.
- 94% of all attended fires were classified as scrub or bush and grass mixture fires; 3.5% classified as small vegetation fires; 1.3% as grassfires; and only 0.2% classified as forest or wood fires greater than one hectare in size.
- Analysis of causal information between 2000-2001 to 2001-2002 revealed 76.7% of vegetation fires were of deliberate origin; 14.8% were accidental; and only 1.6% were started from natural causes (lightning strikes etc).

### 2.1.5.2 Shire of Serpentine Jarrahdale

There is no evidence of increased incidence of bushfire at the site or surrounding locality compared to the greater region. No evidence of previous bushfire behaviour was identified during site inspection. The Shire of Serpentine Jarrahdale reports two previous vegetation fires within the greater site location in the past two years; and one case of arson in a derelict house (Johnson, 2014).

## 2.1.6 Strategic Bushfire Hazard Assessment

Strategic Bushfire Hazard Assessment completed in accordance with FESA (2010) is conducted on the *predominant* vegetation type for the site. Figure 2C (Appendix 1) illustrates the predominant site vegetation as a combination of woodland and shrubland. This represents a moderate bushfire hazard as defined by FESA (2010), in the areas west of the development site. All other areas are identified as a low bushfire hazard. Following the strategic threat levels identified from the aerial imagery, a site assessment was completed. Overall the site is identified as being subject to moderate bushfire hazard suitable for development on the provision heat flux mitigation measures are incorporated as detailed within this plan. These areas are within the locality drainage system and are to be maintained in their natural state. The Shire of Serpentine Jarrahdale expects that “at maturity the reserve will be a moderate to extreme fire hazard” (Johnson, 2014, p1).

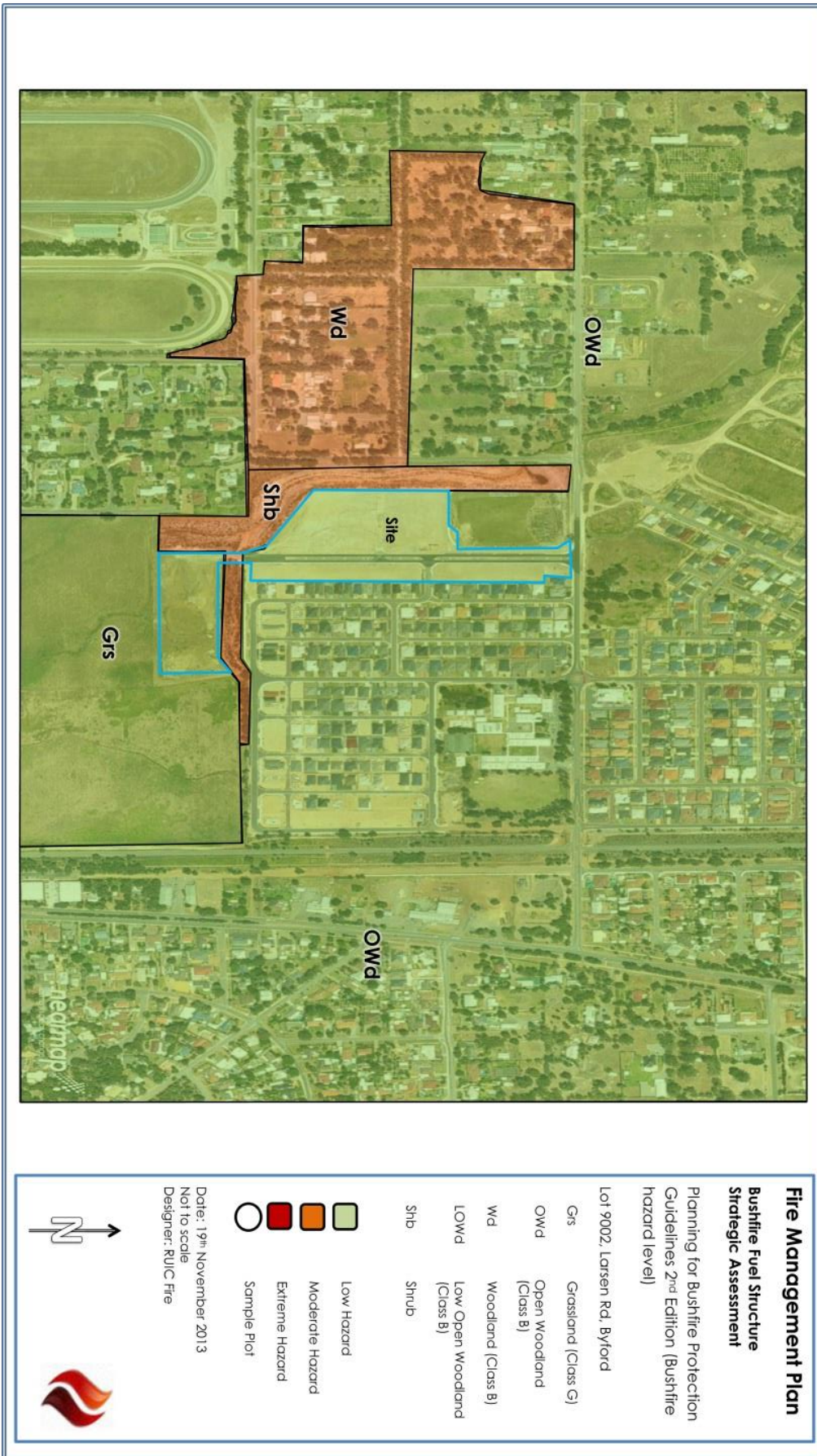

Figure 2C: Strategic Vegetation Assessment



### 2.1.7 Threat Analysis using the Rural Urban Threat Analysis Tool

The RUBTA is designed to identify where a more significant potential problem may exist when compared with other areas after completing a threat analysis of the jurisdiction or assessment zone (FESA, 2003). It is developed specifically for use at the rural urban interface as a risk assessment tool for fire officers and planners; however may be inconsistent with the process detailed in ISO 31000 (2009); COAG (2004) or AS3959 (2009). Comparative analysis of current and post development states is provided in Table 2A.

Hazard levels are shown to significantly decrease post development as a direct result of reduction in site fuel structures and establishment of Building Protection Zones. This contributes to an overall decrease in the bushfire threat to the site and surrounding lots from within the site area.

Element	Current		Post Development	
	Result	Score	Result	Score
Likelihood of occurrence (risk of ignition)	Low	0	Low	0
Fuel load > standard (intensity)	No	0	No	0
Vegetation assessment area with fire hazard (manageability)	Medium	0	Medium	0
Hazard reduction < 80% assessment zone	Yes	1	Yes	1
High visitor usage	No	0	No	0
Recent or proposed residential and industrial developments*	Yes	0	Yes	0*
<b>Total Hazard Assessment</b>	<b>Score – 1 Low</b>		<b>Score – 1 Low</b>	
Easily accessible	No	0	No	0
Response time > 30 minutes	No	0	No	0
Inadequate water supply	No	0	No	0
Inadequate resources	Yes**	1	Yes**	1
<b>Total Management Assessment</b>	<b>Score – 1 Low</b>		<b>Score – 1 Low</b>	

\*Proposed residential development in this instance will result in increased fuel load reduction through enhanced BPZ's and additional compliance required in accordance with the Local Government Fuel Hazard Reduction and Fire Break Notice

\*\*Resources may be inadequate to respond to catastrophic bushfire event such as the Roleystone-Kelmscott bushfire of 2011.

Table 2A: Rural Urban Bushfire Threat Analysis (FESA, 2003)

### 2.1.8 Conclusion

The proposed development is located in an urban development area with extensive areas of low threat/no vegetation. The drainage channel system consists of small isolated pockets of moderate – very high bushfire hazards. Post development the hazard level of the site will remain the same when assessed in accordance with the Strategic Level Assessment (FESA, 2010) and the Rural Urban Threat Analysis Tool (FESA, 2003) as the areas of concern are protected environmental areas.



The site has not yet been designated a Bushfire Prone area by the Shire of Serpentine Jarrahdale. Whilst this Fire Management Plan assesses the site without AS3959:2009 compliance it is important to acknowledge designation of the site as a Bushfire Prone area will only serve to increase the bushfire survivability of new dwellings. In accordance with Bushfire Prone designation all Class 1,2 and 3 buildings within 100m of vegetation assessed as a bushfire threat will be subject to compliance with additional construction standards as specified in *AS3959:2009 Construction of buildings in bushfire prone areas*. This will ultimately increase the bushfire survivability of future dwellings within the site in comparison to existing dwellings in neighbouring areas as a direct result of increased engineering.

In conclusion the bushfire risk to the proposed development is not considered unreasonable and should not prohibit development of the site subject to the measures detailed in this Fire Management Plan being complied with.



## 3.0 Design Bushfire

---

### 3.1 Introduction

Quantified modelling of bushfire behaviour utilising predetermined “worst case” parameters, otherwise known as “design bushfire,” remains the corner stone of conducting evaluation of performance base design (Kashef, Viegas, Mos & Harvey, 2012). The design fire remains a hypothetical model specifically intended to represent the worst case bushfire event possible within the assessment area. Parameters of design bushfire for the assessment area are identified as being:

- Bushfire Weather (inclusive of FDI);
- Site Topography; and
- Bushfire fuel structure and fuel load

In turn the design bushfire is expressed as components of potential fire behaviour which are used to calculate the radiant heat flux and Bushfire Attack Levels applicable to the development. Through application of the design bushfire theory the development is specifically engineered to withstand intense bushfire behaviour during catastrophic FDI and blow up weather conditions.

#### 3.1.1 Bushfire Weather

##### 3.1.1.1 Climate & Bushfire Danger Period

Data collected from the closest Bureau of Meteorology weather station (Medina Research Station - 009194) indicates that the site experiences a temperate climate characterised by mild winter periods and hot, dry summers (Appendix 2). The bushfire danger period occurs during the dryer summer months where grass curing has occurred and humidity is low.

The fire season as deemed by local authorities as between Spring and Autumn. The following fire restrictions apply for the 2012/13 Fire Season:

- |   |   |
|---|---|
| • Restricted Burning Period (Permit Required)                 | 1 <sup>st</sup> October – 30 <sup>th</sup> November |
| • Prohibited Burning Period (No Burning & No Fires Permitted) | 1 <sup>st</sup> December – 31 <sup>st</sup> March   |
| • Restricted Burning Period (Permit Required)                 | 1 <sup>st</sup> April – 31 <sup>st</sup> May        |

##### 3.1.1.2 Fire Danger Index

Section 1.5.12 of AS3959-2009 defines Fire Danger Index (FDI) as

“The chance of a fire starting, its rate of spread, its intensity and the difficulty of its suppression, according to various combinations of air temperature, relative humidity, wind speed and both the long- and short-term drought effects.”

AS3959 defines the FDI in Western Australia as 80. An FDI of 100 representing catastrophic conditions is used for design fire modelling through the Site Assessment Area.



### 3.1.1.3 Wind

Windrose profiles for summer months indicate predominantly morning east to south easterly 40+kph winds; with an almost even distribution of south westerly 40+kph winds by 1500hrs. Wind is a significant contributor to bushfire behaviour, in particular when changes in wind direction result in a bushfire flank turning into a running head fire. Wind speed of 45kph is utilised for design bushfire modelling in shrubland.

### 3.1.2 Site Topography

The development site is flat throughout its entirety. Maximum effective slope is identified as 4<sup>0</sup> downslope, (Appendix 3), which is present for the slopes of the drainage areas to the level of the development site.

### 3.1.3 Bushfire Fuel Structure & Load

The arrangement of bushfire fuel has significantly greater effect on potential fire behaviour than fuel load (Hines, Tolhurst, Wilson & McCarthy, 2010). In conjunction with the Visual Fuel Load Guide (FESA, 2007 & 2012); and AS3959:2009, assessment of Class C Shrubland and Class G Grassland fuel structures in accordance with Overall Fuel Hazard Guide, 2<sup>nd</sup> Edition (DENR, 2012), allows separate assessment of bark; elevated; near-surface; and surface fuels to provide more accurate quantification of potential fire intensity.

Fuel assessment was conducted at plots throughout the site. Assessments are representative of the average fuel structure across the sampling locations. Calculated fuel loads are identified in Table 3B. Fuel structures are illustrated in Plates 1-8.

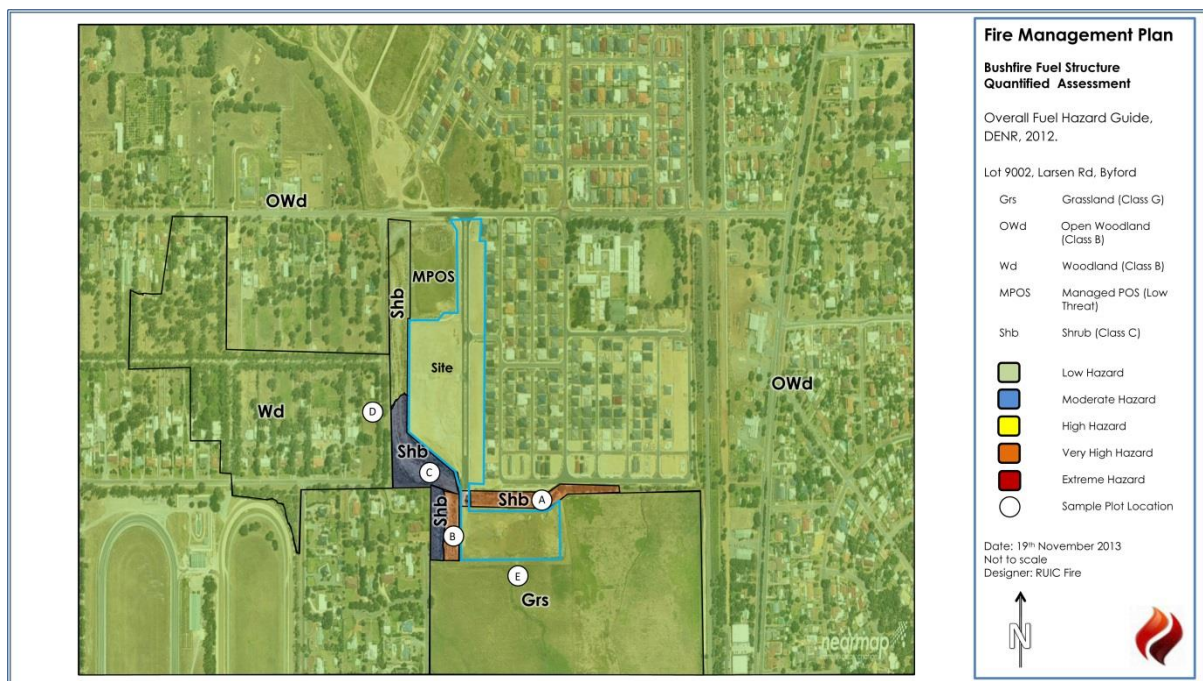

Figure 3A: Sample Plot Locations





Plot	AS3959 Class	Vegetation Type	Bark Fuel Hazard	Elevated Fuel Hazard	Near Surface Fuel Hazard	Surface Fuel Hazard	Combined Surface and Near Surface Fuel Hazard	Overall Fuel Hazard	
A	Class C	Shrubland	L	VH	VH	L	H	VH	
B	Class C	Shrubland	L	VH	H	L	M	VH	
C	Class C	Shrubland	L	M	H	L	M	M	
D	Low Threat	Open Woodland	L	L	L	L	L	Low Threat	
E	Low Threat	Grassland	L	L	L	M	L	Low Threat	
<b>L</b>	<b>LOW</b>	<b>M</b>	<b>MODERATE</b>	<b>H</b>	<b>HIGH</b>	<b>VH</b>	<b>VERY HIGH</b>	<b>E</b>	<b>EXTREME</b>

Table 3A: Hazard Assessment (DENR, 2012; AS3959-2009)

Plot	A	B	C	D	E
Bark Fuel Load (t/ha)	0	0	0	N/A	N/A
Elevated Fuel Load (t/ha)	6	6	0	N/A	N/A
Surface Fuel Load (t/ha)	10	5	5	N/A	N/A
Overall Fuel Load (t/ha)	16	11	5	N/A	N/A

Table 3B: Fuel Load Calculation (FESA, 2012; DENR, 2012)

Highest fuel load is identified as 16 t/ha through the Class C Shrubland vegetation located at the rear, south end, of the proposed stage 4 development lots. Fuel loads in areas of Class G Grassland can be reduced through minor fuel hazard reduction works or grazing. Grazed Class G Grassland (Plot E) and Open Woodland (Plot D) constitute Low Threat Vegetation in accordance with AS3959:2009 s2.2.3.2 suitable for inclusion as part of Building Protection Zones as defined in FESA (2010).



Plate 1: South of Stage 4 (Plot A)



Plate 2: South of Stage 4 (Plot A)



*Plate 3: West from Stage 5 (Plot B)*



*Plate 4: West from Stage 5 (Plot B)*



*Plate 5: Class C Shrubland (Plot C)*



*Plate 6: Class C Shrubland (Plot C)*



*Plate 7: Low Threat (Plot D)*



*Plate 8: Low Threat (Plot E)*



### 3.2 Design Bushfire Heat Flux & BAL

The purpose of this indicative Bushfire Attack Level (BAL) Assessment is to demonstrate the ability of the potential subdivision to comply with Performance Criteria P1 as required in FESA's Planning for Bushfire Protection Guidelines 2<sup>nd</sup> Edition. The Bushfire Attack Level (BAL) is determined in accordance with AS3959 2<sup>nd</sup> Methodology in accordance with design bushfire fuel load parameters of the indicative subdivision. Increased design safety is engineered into each Heat Flux calculation through the design fire process; specifically the use of an FDI of 100 (125% of the FDI assigned to Western Australia in AS3959:2009); and utilisation of maximum Shrubland fuel load (107% of the Fuel Load assigned in AS3959:2009). Heat flux calculations in accordance with AS3959:2009 Methodology 2 are summarised in Table 3C for Class C Shrubland.

It is essential to note the BAL Table published in Appendix 1 of Planning for Bushfire Protection Guidelines 2<sup>nd</sup> Edition (FESA, 2010) contains errors that result in setbacks for Class C Shrubland and Class D Scrub being reversed (ie Class C Shrubland for Class D Scrub and visa versa). Use of the incorrect table can result in incorrect determination of BAL if used.

Class C Shrubland (Effective Slope: Downslope 4°)	
Setback from Vegetation	Bushfire Attack Level (BAL)
0 to < 6.5m	FZ
6.5 to < 8.5m	40
8.5 to < 13m	29
13 to < 19.5m	19
19.5 to 100m	12.5
Greater than 100m	Low

Table 3C: Indicative BAL vs Setback Class C Shrubland

Highest potential heat flux impact is identified as resulting from Class C Shrubland originating below existing and potential dwelling sites. Establishment of Building Protection Zone and Hazard Separation Zone of a minimum of 8.5m distance ensuring a maximum BAL-29 rating to all proposed dwellings.

### 3.3 Conclusion

Design of potential subdivisions must include measures to reduce the risk from bushfire. Design must incorporate bushfire safety engineering analysis to ensure potential bushfire behaviour will be reduced so that it can be safely combated by firefighting agencies should it reach the proposed development.

Analysis of heat flux impact in design bushfire conditions incorporating safety measures exceeding Australian Standard 3959:2009 demonstrate the proposed rezoning will facilitate subdivision compliant with Performance Criteria P1 as required in FESA's Planning for Bushfire Protection Guidelines 2<sup>nd</sup> Edition (2010).



## 4.0 Bush Fire Risk Mitigation

---

The bush fire risk mitigation strategies detailed in this report are designed to comply with the Performance Criteria and Acceptable Solutions detailed in the Planning for Bush Fire Protection Guidelines 2<sup>nd</sup> Edition.

- The notation (P3) refers to Performance Criteria 3 of the Planning for Bush Fire Protection Guidelines 2<sup>nd</sup> Edition. The notation (A3.1) refers to Acceptable Solution 3.1 of the Planning for Bush Fire Protection Guidelines 2<sup>nd</sup> Edition.
- The notation (E3.1) refers to Explanatory Note 3.1 of the Planning for Bush Fire Protection Guidelines 2<sup>nd</sup> Edition.
- The notation (SJ43) refers to Serpentine Jarrahdale Shire, Local Planning Policy No.43, Hazards and Natural Disasters.
- Where discrepancy occurs between Planning for Bushfire Protection Guidelines 2<sup>nd</sup> Edition and the Local Government Fuel Reduction and Firebreak Notice the higher standard of mitigation has been selected.

The elements of this Fire Management Plan are designed having due regard for the Landscape Management Plan (GHEMS, 2011) as provided by the client.

### 4.1 Element 1 - Location of Development

#### Intent

To ensure that development/intensification of land use is located in areas where the bush fire hazard does not present an unreasonable level of risk to life and property

#### Performance Criteria (P1)

The subdivision/development is located in an area where the bush fire hazard level is manageable.

#### Design Solutions

The intent of Element 1 is upheld and Performance Criteria (P1) is met through Acceptable Solutions 1-3.

##### Acceptable Solution 1      **General Site Location**

The proposed development is subject to an increased level of bushfire risk from the vegetation within the drainage systems. The current risk to proposed dwellings at the site can be reduced subject to the development meeting the requirements of this report. (P1)

##### Acceptable Solution 2      **Managed Bushfire Threat**

Bushfire safety engineering supported setbacks from identified vegetation threats and establishment of the Building Protection and Hazard Separation Zones, through POS, low threat vegetation and



established concrete footpaths, ensure that the development is located in an area when the bushfire hazard does not present an unreasonable level of risk to life and property. (P1)

### Acceptable Solution 3      **Development Location**

The subdivision is not located within an extreme bushfire hazard area, as determined by detailed site assessment.

---

## **4.2 Element 2 - Vehicular Access**

### **Intent**

To ensure that the vehicular access serving a subdivision/development is safe in the event of a bush fire occurring

### **Performance Criteria (P2)**

The internal layout, design and construction of public and private vehicular access in the subdivision/development allow emergency and other vehicles to move through it easily and safely at all times.

### **Design Solutions**

The intent of Element 2 is upheld and Performance Criteria (P2) is achieved through Acceptable Solutions 4-7.

---

### Acceptable Solution 4      **Access and Egress**

The proposed subdivision constitutes infill development connecting to an existing public road network. Larsen Road borders the northern boundary of the site and provides egress to the west and east directions, via Sansimeon Boulevard and Padra Turn.

### Acceptable Solution 5      **Vehicle Access**

The existing internal road network throughout the site provides comprehensive vehicle access throughout the property for both private and emergency services vehicles. It also facilitates multiple egress routes through areas of low threat. Internal road access is available within 50m of all dwelling sites. No additional clearing of covenanted vegetation is required to maintain the internal road structure.

#### (a) Construction Standards:

- i.      trafficable surface: 6 metres
- ii.     horizontal clearance: 6 metres
- iii.    vertical clearance: total vertical clearance
- iv.    grade not exceeding: 10°
- v.     minimum weight capacity: 15 tonnes
- vi.    maximum crossfall: 1 in 33
- vii.   curves minimum inner radius: 12 metres



- viii. passing bays every 200m:
  - a. length: 20m
  - b. width: 2m (so that combined private driveway and passing bay is 6m)
- (a) Implementation:
  - i. Prior to clearance
- (b) Development:
  - i. It is the responsibility of the developer to ensure public roads meet the required construction standards
- (c) Maintenance:
  - i. It is the responsibility of the Local Government to ensure public roads continue to meet the required construction standards.

### Acceptable Solution 6 **Cul-de-sac**

No cul-de-sacs are currently incorporated into the design. Should future versions of the plan be developed involving cul-de-sacs they shall meet the requirements as set in Planning for Bush Fire Protection Guidelines 2<sup>nd</sup> Edition acceptable solutions A2.5 with the exception of grade requirements which are aligned with Planning for Bush Fire Protection 2006, NSW Rural Fire Service due to error in grade specifications in FESA's Planning for Bush Fire Protection Guidelines 2<sup>nd</sup> Edition..

- (a) Construction Standards:
  - i. trafficable surface: 6 metres
  - ii. horizontal clearance: 6 metres
  - iii. vertical clearance: total vertical clearance
  - iv. grade not exceeding: 10°
  - v. minimum weight capacity: 15 tonnes
  - vi. maximum crossfall: 1 in 33
  - vii. curves minimum inner radius: 12 metres
  - viii. heads: 21m turnaround or as detailed below (Ref: FESA, 2010 p35 "Turning areas"):

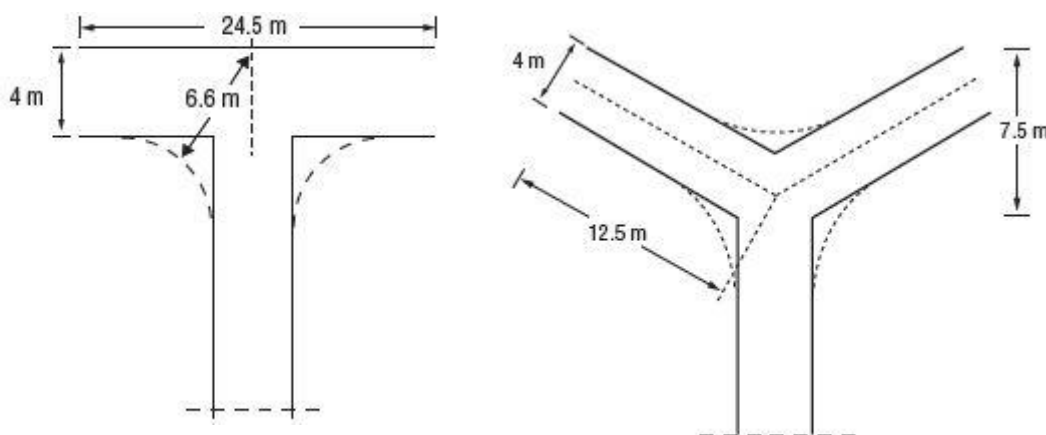

- (b) Implementation:
  - i. Prior to clearance



- (c) Development:
  - i. It is the responsibility of the developer to ensure the cul-de-sacs meet the required construction standards
- (d) Maintenance:
  - i. It is the responsibility of the Local Government to ensure the cul-de-sacs continue to meet the required construction standards.

#### Acceptable Solution 7      **Battle Axes**

The existing design does not incorporate Battle Axe lots. Should future versions of the plan be developed involving Battle Axe lots they shall meet the requirements as set in Planning for Bush Fire Protection Guidelines 2<sup>nd</sup> Edition acceptable solutions A2.4 with the exception of grade requirements which are aligned with Planning for Bush Fire Protection 2006, NSW Rural Fire Service due to error in grade specifications in FESA's Planning for Bush Fire Protection Guidelines 2<sup>nd</sup> Edition..

- (a) Construction Standards:
  - i. Length: not more than 600m
  - ii. trafficable surface: 6 metres
  - iii. horizontal clearance: 6 metres
  - iv. vertical clearance: total vertical clearance
  - v. grade not exceeding: 10°
  - vi. minimum weight capacity: 15 tonnes
  - vii. maximum crossfall: 1 in 33
  - viii. curves minimum inner radius: 12 metres
- (b) Implementation:
  - i. Prior to clearance
- (c) Development:
  - i. It is the responsibility of the developer to ensure all Battle Axe lots meet the required construction standards
- (d) Maintenance:
  - i. It is the responsibility of individual land owners to ensure individual Battle Axe lots continue to meet the required construction standards.

---

### 4.3 Element 3 – Water Supply

#### **Intent**

To ensure that water is available to the development to ensure life and property to be defended from a bush fire.

#### **Performance Criteria (P3)**

The development is provided with a permanent and secure water supply that is sufficient for fire fighting purposes.

#### **Design Solutions**



The intent of Element 3 is upheld; and Performance Criteria (P3) achieved through Acceptable Solution 8.

---

Acceptable Solution 8      **Firefighting Water**

The development is provided with a reticulated water supply, together with fire hydrants, in accordance with the specifications of the relevant water supply authority and DFES.

---

#### **4.4 Element 4 – Siting of Development**

##### **Intent**

To ensure that the siting of development minimises the level of bush fire impact.

##### **Performance Criteria (P4)**

The siting (including paths and landscaping) of the development minimises the bush fire risk to life and property.

##### **Design Solutions**

The intent of Element 4 is upheld and Performance Criteria (P4) are achieved through Acceptable Solution 9.

---

Acceptable Solution 9      **Building Protection & Hazard Separation Zones**

The building protection zone is a low fuel area immediately surrounding a building and is designed to minimise the likelihood of flame contact with buildings. Features such as driveways, footpaths, roads, vegetable patches, lawn or landscaped garden (including deciduous trees and fire resistant plant species) may form part of building protection zones. Areas of vegetation deemed Low Threat Vegetation and managed in a reduced fuel state inclusive of Public Open Space and nature strips may form part of a dwellings defensible space. Isolated shrubs and trees may be retained within building protection zones.

Due to the residential density of housing in this development, the building protection and hazard separation zones will overlap between individual lots adjacent to identified vegetation. The Shire of Serpentine Jarrahdale has identified the requirement for all dwellings to be constructed to AS3959:2009 in accordance with the individual threat to each property (Johnson, 2014). Individual BAL assessments are to be conducted for each proposed dwelling as required by the Shire of Serpentine Jarrahdale.

(i)      **Building Protection Zone**

(a) Construction Standards:

- i. width: 10m ensure maximum BAL-29 rating (refer to Table 3D for required setbacks);





- ii. Footpath to be installed external to the outer property boundaries where classified vegetation is identified.
  - iii. trees are low pruned at least to a height of 2 metres
  - iv. no tall shrub or tree is located within 2 metres of a building (including windows)
  - v. there are no tree crowns overhanging the building
  - vi. shrubs in the building protection zone have no dead material within the plant
  - vii. tall shrubs in the building protection zone are not planted in clumps close to the building ie within 3 metres
  - viii. trees in the building protection zone have no dead material within the plant's crown or on the bole.
  - ix. Leaf litter shall not be exceed 50% surface coverage or a depth of 10mm
  - x. Near surface and elevated bushfire fuels are not permitted in the BPZ
- (b) Implementation:
- i. Prior to habitation of any new dwelling.
- (c) Development:
- i. It is the responsibility of the developer to ensure all Building Protection Zones meet the required construction standards.
- (d) Maintenance:
- i. It is the responsibility of the individual land owner to ensure all Building Protection Zones continue to meet the required construction standards.

**(ii) Hazard Separation Zone**

- (a) Construction Standards:
- i. width: 90m from the boundary of all Building Protection Zones;
  - ii. in accordance with the Shire of Serpentine Jarrahdale's requirements for drainage.
- (b) Implementation:
- i. n/a.
- (c) Development:
- i. n/a.
- (d) Maintenance:
- i. The Shire of Serpentine Jarrahdale have identified the drainage reserve shall be maintained in a state as required to meet drainage performance standards. This will result in the vegetation being a moderate to extreme fire hazard at maturity.

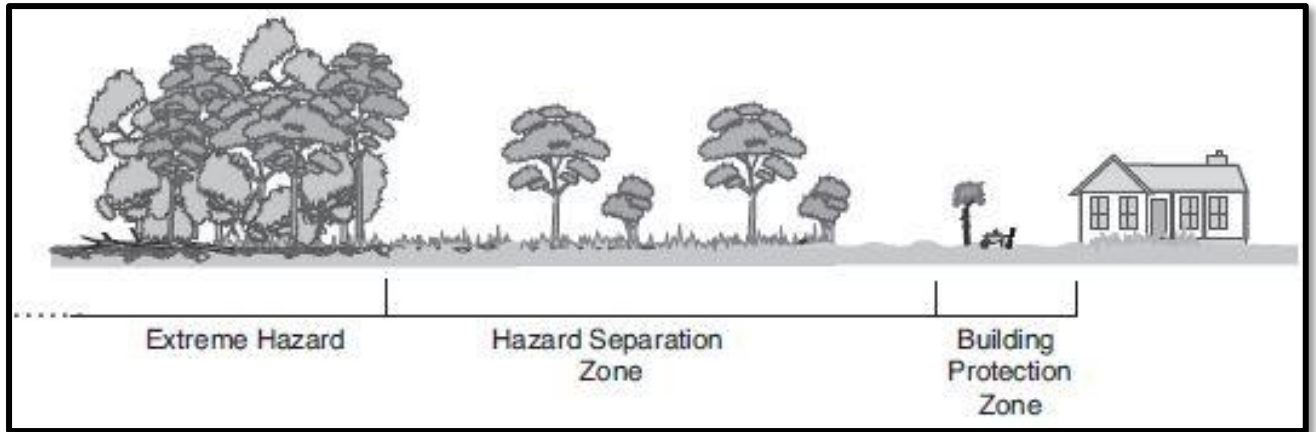

Figure 4A: Building Protection and Hazard Separation Zones (FESA, 2010, p.44)

## 4.5 Element 5 – Design of Development

### Intent

To ensure that the design of the development minimises the level of bush fire impact.

### Performance Criteria (P5)

The design of the development is appropriate to the level of bush fire hazard that applies to the development site.

### Design Solutions

The intent of Element 5 is upheld and Performance Criteria (P5) is achieved through Acceptable Solution 10.

---

#### Acceptable Solution 10      Design of Development

This design utilises Acceptable Solutions to ensure the Intent and Performance Criteria of all Elements are met.

## 4.6 Element 6 – Additional Provisions

### Intent

To address bushfire risk not covered in Planning for Bushfire Protection Guidelines 2<sup>nd</sup> Edition or detailed previously in the report.

### Provisions

The following ongoing Fire Risk Mitigation Strategies are to apply:

- i. Any amendments to this FMP shall be approved by the Shire of Serpentine Jarrahdale.
- ii. This report shall be registered as an s70A notification on the title of all properties this report is applicable to.



- iii. A copy of this report shall be provided to any prospective purchaser prior to the sale of any property covered by this report.

#### 4.7 Works and Responsibilities

This table summarises the responsible party for each mitigation strategy and the time frame in which it must be completed:

Strategy	Implementation		Maintenance	
	Responsible	Time Frame	Responsible	Time Frame
Building Protection Zones	Developer	Prior to clearance	Individual Land Owner	Ongoing
Cul-de-sacs	Developer	Prior to clearance	Local Government	Ongoing
Firefighting Water	Developer	During Site works	Water Authority	Ongoing
Hazard Separation Zones	Local Government	Ongoing	Local Government	Ongoing
Landscaping of Public Open Space	Local Government	Ongoing	Local Government	Ongoing
Vehicle Access	Developer	During Construction	Local Government	Ongoing

Table 4A: Schedule of Works



## 5.0 Compliance Checklist for Performance Criteria and Acceptable Solutions

### 5.1 Bushfire hazard levels and performance criteria

Level of bushfire hazard	Bushfire protection performance criteria
Low hazard	Development does not require special bushfire planning controls. Despite this DFES strongly recommends that ember protection features be incorporated in design where practicable.
Moderate hazard	Performance criteria for: <ul style="list-style-type: none"> <li>• location (P1)</li> <li>• vehicular access (P2)</li> <li>• water (P3)</li> <li>• siting of development (P4)</li> <li>• design of development (P5)</li> </ul>
Extreme hazard	Development is to be avoided in areas with these hazards

Table 5A: Bushfire hazard levels and performance criteria (FESA, 2010)

### 5.2 Performance Criteria and Compliance

The site has been assessed as having a moderate hazard level and is therefore subject to meeting the performance criteria as detailed. It is important to note that the acceptable solutions listed in *Planning for Bushfire Protection Guidelines 2<sup>nd</sup> Edition* only illustrate “one example of meeting the associated performance criteria” (FESA, 2010, p.28). Where an acceptable solution may not be suitable a performance solution may be implemented. Justification of Performance Solutions is provided in the section 4 of this report.

Element	Acceptable Solution	Compliance	Yes/No	Acceptable Solution (AS) or Performance Based Solution (PBS)
1. Location	A1.1 Development location	Does the proposal comply with performance criteria P1 by applying acceptable solution A1.1?	YES	AS 1 AS 2 AS 3
2. Vehicular Access	A2.1 Two access routes	Does the proposal comply with performance criteria P2 by applying acceptable solution A2.1?	YES	AS 4
	A2.2 Public roads	Does the proposal comply with performance criteria P2 by applying acceptable solution A2.2?	YES	AS 5
	A2.3 Cul-de-sacs	Does the proposal comply with performance criteria P2 by applying acceptable solution A2.3?	YES	AS 6
	A2.4 Battle axes	Does the proposal comply with performance criteria P2 by applying acceptable solution A2.4?	YES	AS 7
	A2.5 Private driveways	Does the proposal comply with performance criteria P2 by applying acceptable solution A2.5?	N/A	
	A2.6 Emergency access ways	Does the proposal comply with performance criteria P2 by applying acceptable solution A2.6?	N/A	
	A2.7 Fire service access routes	Does the proposal comply with performance criteria P2 by applying acceptable solution A2.7?	N/A	
	A2.8 Gates	Does the proposal comply with performance	N/A	



		criteria P2 by applying acceptable solution A2.8?		
	A2.9 Firebreak widths	Does the proposal comply with performance criteria P2 by applying acceptable solution A2.9?	N/A	
	A2.10 Signs	Does the proposal comply with performance criteria P2 by applying acceptable solution A2.10?	N/A	
3. Water	A3.1 Reticulated supply	Does the proposal comply with performance criteria P3 by applying acceptable solution A3.1?	YES	AS 8
	A3.2 Non reticulated areas – water tanks	Does the proposal comply with performance criteria P3 by applying acceptable solution A3.2?	N/A	
	A3.3 Non reticulated areas - dam	Does the proposal comply with performance criteria P3 by applying acceptable solution A3.3?	N/A	
4. Siting of development	A4.1 Hazard separation – moderate to extreme bush fire hazard level	Does the proposal comply with performance criteria P4 by applying acceptable solution A4.1?	YES	AS9
	A4.2 Hazard separation – low bush fire hazard level	Does the proposal comply with performance criteria P4 by applying acceptable solution A4.2?	N/A	
	A4.3 Building protection zone	Does the proposal comply with performance criteria P4 by applying acceptable solution A4.3?	YES	AS 9
	A4.4 Hazard separation zone	Does the proposal comply with performance criteria P4 by applying acceptable solution A4.4?	YES	AS 9
	A4.5 Reduction in bushfire attack due to shielding	Does the proposal comply with performance criteria P4 by applying acceptable solution A4.5?	N/A	
5. Design of development	A5.1 Compliant development	Does the proposal comply with performance criteria P5 by applying acceptable solution A5.1?	YES	AS 10
	A5.2 Non-compliant development	Does the proposal comply with performance criteria P5 by applying acceptable solution A5.2?	N/A	

Table 5B: Performance Criteria Compliance

### 5.3 Conclusion

This Fire Management Plan demonstrates compliance of the proposed subdivision with all relevant criteria in Planning for Bushfire Protection Guidelines 2<sup>nd</sup> Edition (FESA, 2010). Bushfire engineering incorporating design bushfire parameters ensures potential heat flux impact on dwellings exceeds the levels determined in accordance with AS3959:2009. In undertaking the risk mitigation procedures identified in this Fire Management Plan the client is demonstrating due diligence (Robinson et al., 2011) in regards to bushfire risk.



## 6.0 References

---

- AS3959 *Construction of buildings in bushfire prone areas* (2009).
- ISO31000 *Risk management principles and guidelines*
- State Planning Policy 3.4 *Natural Hazards* (2006). West Australian Planning Commission, FESA
- Australian Building Codes Board. (2012). *Building Codes of Australia Volume 1: Australian Building Codes Board*.
- BOM (2013). *Climate Data Online*, [www.bom.gov.au](http://www.bom.gov.au) Bureau of Meteorology
- Ellis, S., Kanowski, P., & Whelan, R. (2004). *National Inquiry on Bushfire Mitigation and Management*. Council of Australian Governments
- FESA. (2010). *Planning for Bush Fire Protection Guidelines 2<sup>nd</sup> Edition* Perth: Western Australian Planning Commission Fire and Emergency Services Authority of Western Australia
- FESA. (2012). *Visual Fuel Load Guide*. Perth: Fire and Emergency Services Authority of Western Australia.
- GHEMS Revegetation Environmental (2011). *Landscape Management Plan, Marri Park Private Estate*
- Hines, F., Tolhurst, K., Wilson, A., & McCarthy, G. (2010). *Overall fuel hazard assessment guide* (4th ed.). Victoria: Department of Sustainability and Environment.
- Johnson, J. (2014) *Shire of Serpentine Jarrahdale amendments to draft FMP*. Shire of Serpentine Jarrahdale
- Keith, D. (2004). *Ocean Shores to Ocean Dunes*. Sydney: Department of Environment and Conservation.
- Langdon, (2013) *Site Plan*. Goldtune Investments Pty Ltd
- NSW Rural Fire Service. (2006). *Planning for Bush Fire Protection*. NSW Rural Fire Service.
- Ramsay, C., & Rudolph, L. (2003). *Landscape and Building Design for Bushfire Areas* Victoria: CSIRO Publishing.
- Robinson, R., Francis, G., Dean, M., Kanga, M., Robinson, J., & Stoks, F. (2011). *Risk and Reliability: Engineering Due Diligence* (8th ed.): R2A Pty Ltd.
- RUIC Fire (2013) *Bushfire Attack Level Calculator v4.0*
- Shire of Serpentine Jarrahdale (2011) *Local Planning Policy No.43, Hazards and Natural Disasters*



## 7.0 Appendix 1 – Strategic Vegetation Hazard Assessment

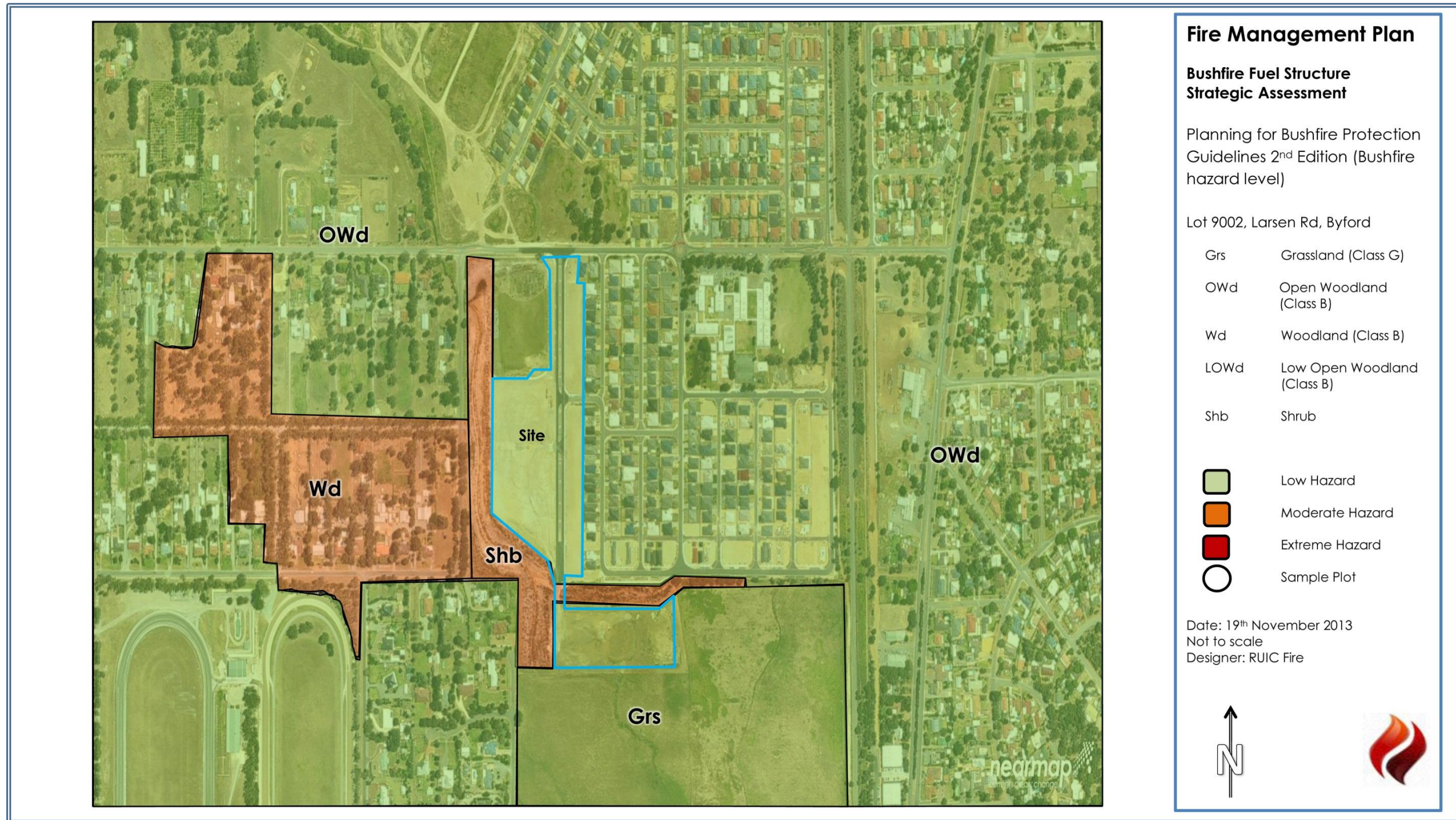



## 8.0 Appendix 2 – Bushfire Weather

Statistics	Jan	Feb	Mar	Apr	May	Jun	Jul	Aug	Sep	Oct	Nov	Dec	Annual
Max Temp (°C)	44.9	45.8	43.3	36.5	32.9	26.2	25.8	26.0	30.9	37.8	41.4	45.0	45.8
Min Rainfall (mm)	0.0	0.0	0.0	2.7	34.7	28.4	39.4	42.8	33.6	7.9	5.0	0.0	487.1
Mean 9am Humidity	53	56	61	67	77	82	83	79	73	65	60	55	68
Mean 3pm Humidity	42	42	44	50	57	63	64	60	58	53	49	45	52

Table 3A: Historical Climate Data (Bureau of Meteorology, 2013, Station 9240)

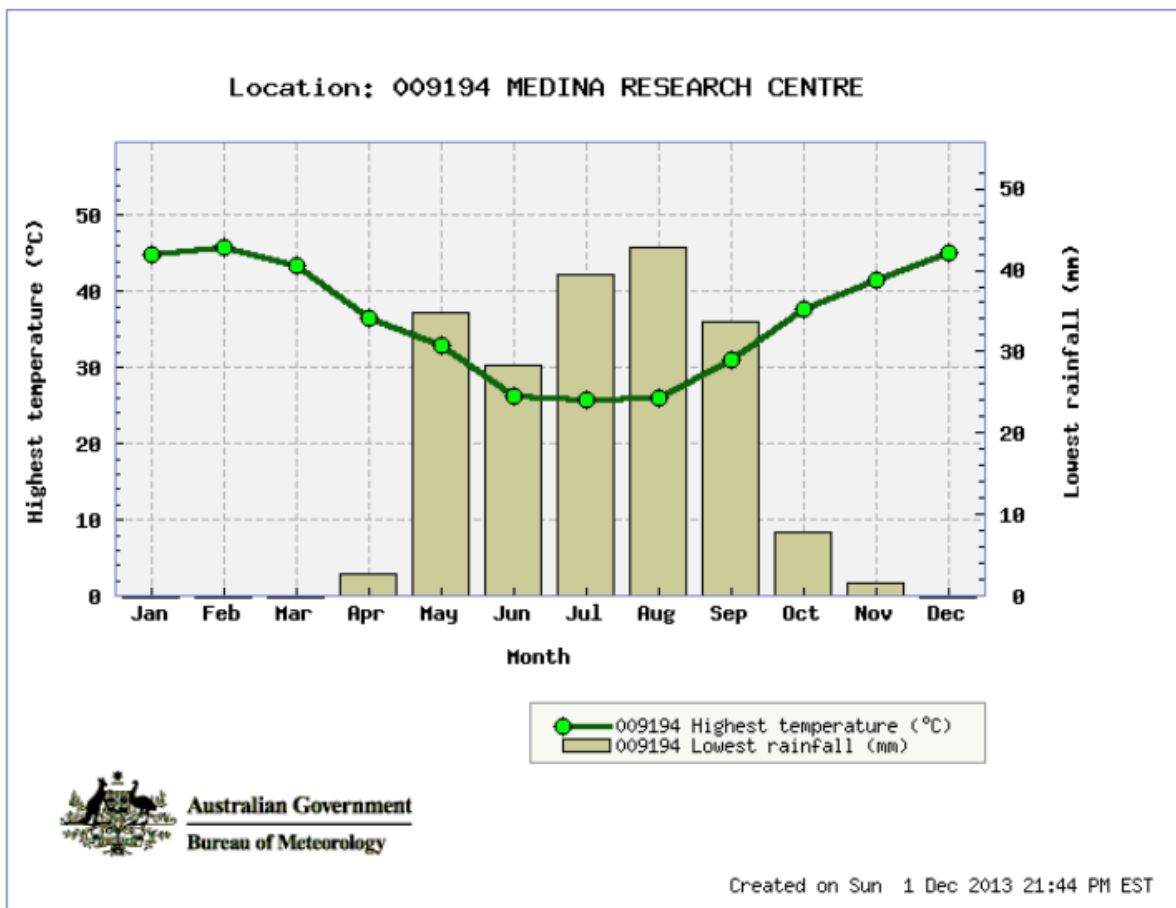
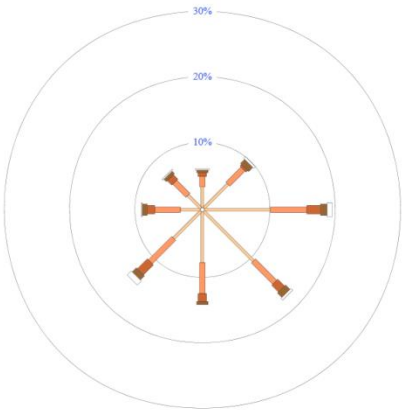
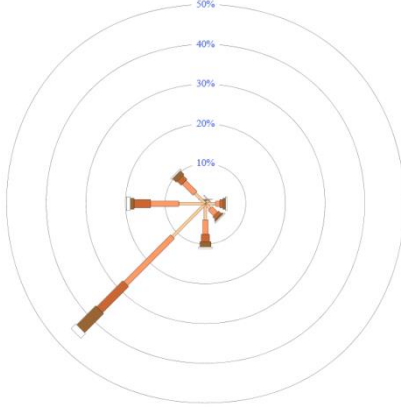
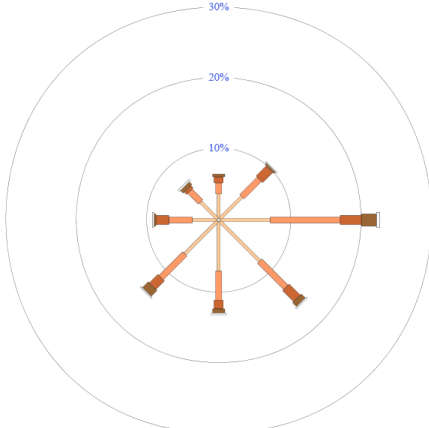
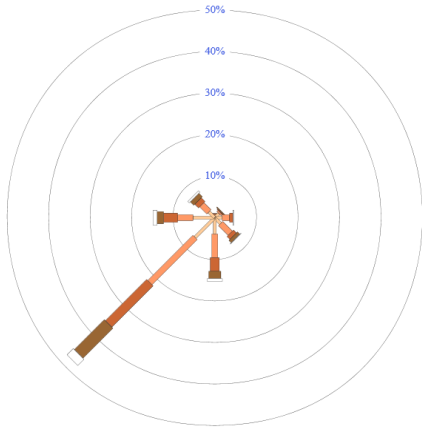
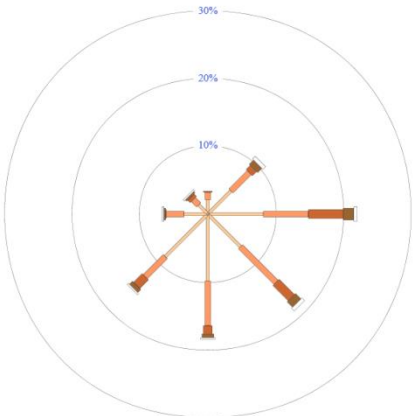
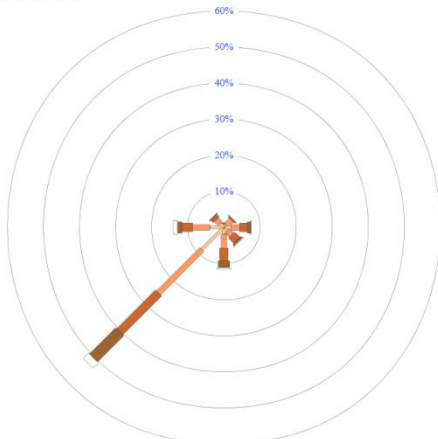

Figure 3A: Maximum temperature (since 1983) vs minimum rainfall (since 1983)





Month	0900hrs	1500hrs
October	<p>9 am Oct 794 Total Observations Calm 2%</p> 	<p>3 pm Oct 540 Total Observations Calm 1%</p> 
November	<p>9 am Nov 770 Total Observations Calm 1%</p> 	<p>3 pm Nov 520 Total Observations Calm *</p> 
December	<p>9 am Dec 800 Total Observations Calm 1%</p> 	<p>3 pm Dec 542 Total Observations Calm *</p> 



<p style="writing-mode: vertical-rl; transform: rotate(180deg);">January</p>	<p>9 am Jan 796 Total Observations Calm 1%</p>	<p>3 pm Jan 532 Total Observations Calm *</p>
<p style="writing-mode: vertical-rl; transform: rotate(180deg);">February</p>	<p>9 am Feb 755 Total Observations Calm 1%</p>	<p>3 pm Feb 518 Total Observations Calm *</p>
<p style="writing-mode: vertical-rl; transform: rotate(180deg);">March</p>	<p>9 am Mar 825 Total Observations Calm 1%</p>	<p>3 pm Mar 555 Total Observations Calm *</p>
<p>Guide</p>		

Table 3B: Windrose profiles (Bureau of Meteorology, 2013, Station 9240)



9.0 Appendix 3 – Site Topography

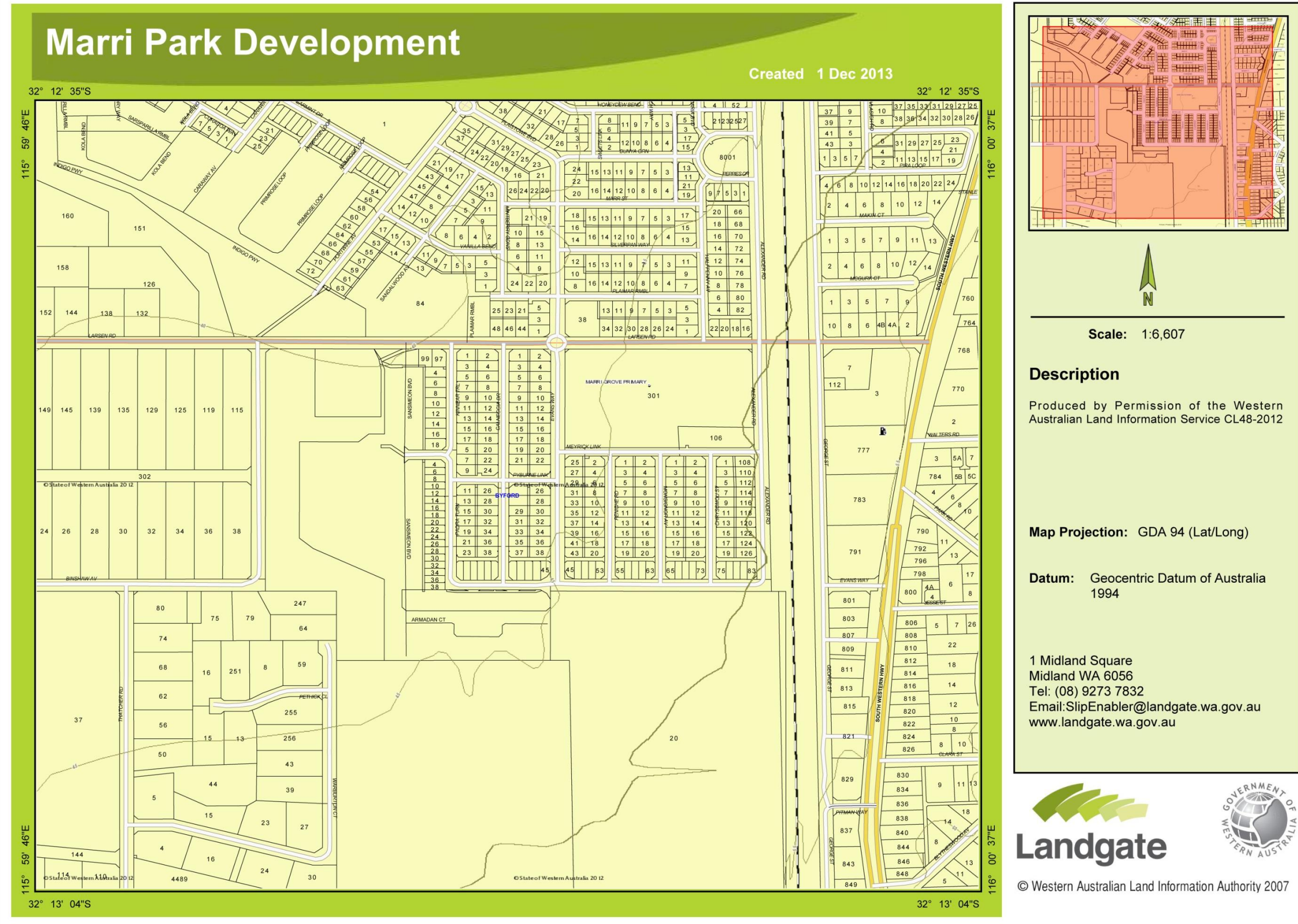



## 10.0 Appendix 4 – Abbreviations & Terms

---

### 10.1 Abbreviations Used in the Fire Management Plan

BPZ	Building Protection Zone
DEC	Department of Environment and Conservation
DFES	Department of Fire and Emergency Services (formerly FESA)
DPAW	Department of Parks and Wildlife (Formerly DEC)
FESA	Fire and Emergency Services Authority of Western Australia
FMP	Fire Management Plan
HSZ	Hazard Separation Zone
WAPC	Western Australian Planning Commission

### 10.2 Terminology Used in the Fire Management Plan

All terminology is sourced from AS3959:2009; Ellis, Kanowski and Whelan (2004); FESA (2011); Ramsay and Rudolph (2003); and *Building Codes of Australia* (2012).

Acceptable risk	That level of risk that is sufficiently low that society is comfortable with it. Society does not generally consider expenditure in further reducing such risks justifiable
Aerial fuel	The standing and supporting combustibles not in direct contact with the ground and consisting mainly of foliage, twigs, branches, stems, bark and creepers
Appliance	A firefighting vehicle, usually equipped with a pump and water supply.
Area of origin	General location where the fire started.
Aspect	The direction towards which a slope faces
Available fuel	The portion of the total fuel that would actually burn under various specified weather conditions.
Available resources	Resources at an incident and available for allocation at short notice
Biodiversity	The variety of nature, including the number of species and the amount of genetic variation present in an area of interest; the range of native plants



	and animals found at a particular site
Buffer	<p>(1) A protective margin of vegetation abutting a stream, spring, wetland, body of standing water, swampy ground or an area of rainforest, which protects it from potentially detrimental disturbances in the surrounding forest. Buffer width is defined as horizontal distance from which various operations are excluded.</p> <p>(2) A protective margin of vegetation around the edge of an area that shields or protects the surrounding vegetation from the effects of a fire or timber harvesting activities, etc.</p> <p>(3) A strip or block of land identified as providing a zone of defined activity or activity limits surrounding a specified area.</p> <p>(4) A fuelbreak.</p>
Burning Debris	Flaming or smouldering branches, twigs, bark or other pieces of ignited material.
Bush	A general term for forest or woodland but normally used to describe indigenous forest
Bushfire	<p>(1) Used synonymously with wildfire to describe an unplanned fire (burning in predominantly native vegetation)</p> <p>(2) A general term used to describe a fire in vegetation</p> <p>(3) An unplanned fire in bush. This is a general term, uniquely used by Australians, and includes grass fires, forest fires and scrub fires—that is, any fire outside the built-up urban environment. Also sometimes known as a wildfire. In the United States it is called a wildfire and sometimes a 'wildland fire'; in Europe and Asia it is usually called a 'forest fire'.</p>
Bushfire danger period	A period of the year, either established by legislation or declared by the relevant agency, when restrictions are placed on the use of fire due to dry vegetation and the existence of conditions conducive to the spread of fire
Bushfire threat	<p>A term used to describe and analyse the danger that a bushfire poses in a particular place, or to specified values. There are four aspects:</p> <p>(1) the risk of a fire starting, and of it becoming uncontrollable;</p> <p>(2) the values which will be lost or damaged if a bushfire starts and gets away;</p>



	<p>(3) the extent of damage which could be caused; and</p> <p>(4) the resources which can be brought to bear on a fire and their efficiency and effectiveness.</p>
Bushfire prone area	Land which has been designated under a power of legislation as being subject, or likely to be subject, to bushfires.
Canopy	The crown of a tree.
Climate	The atmospheric conditions of a place over an extended period of time.
Coarse fuel	Dead fuel of diameter greater than 6mm, such as logs and large branchwood
Consequence	The outcome of an event expressed qualitatively or quantitatively, being a loss, injury, disadvantage or gain. There may be a range of possible outcomes associated with an event
Crown fire	A fire burning in the crowns of trees.
Crown land	<p>Land that is, or is deemed to be, unalienated land of the Crown. It includes:</p> <p>(1) land of the Crown reserved permanently or temporarily or set aside by or under an Act;</p> <p>(2) land of the Crown occupied by a person under a lease, licence or other right</p>
Dead fuels	Fuels having no living tissue. Their moisture content is governed almost entirely by atmospheric moisture (relative humidity and precipitation), air temperature and solar radiation.
Drought factor	A broad measure of fuel availability as determined by drought index and recent rainfall
Drought index	A numerical value, such as the Keetch–Byram Drought Index, reflecting the dryness of soils, deep forest litter, logs and living vegetation
Ecosystem	<p>An assemblage of plants and animals in a particular physical environment</p> <p>A terrestrial ecosystem encompasses a particular biota, the soil, rock outcrops, wetlands and waterways and the atmosphere. Different ecosystems may respond differently to external pressures, for example, a bushfire, a frost, a flood or prolonged drought. The principal focus of the science of ecology is to understand different responses to imposed or natural events, and the many interactions between species and the</p>



	environment.
Elevated dead fuel	Dead fuel forming part of, or being suspended in, the shrub layer.
Elevated fuel	Combustible material that is erect or suspended above the ground surface, and often comprises shrub, heath and suspended material.
Embers	Glowing particles cast from the fire (as 'showers' or 'storms').
Escape route	A situation in which individuals are exposed to life threatening or potentially life threatening conditions from which they cannot safely remove themselves
Catastrophic / formerly extreme (bushfire) conditions	Extreme bushfire conditions occur when the fuel load is high, the temperature is high, the wind strength is high, the drought index is high, the relative humidity is low, and the fuel moisture is low. These conditions can occur every summer Australia. A bushfire occurring under extreme conditions moves rapidly and generates intense heat and is very difficult or impossible to suppress
Catastrophic / formerly extreme fire behaviour	A level of wildfire behaviour characteristics that ordinarily precludes methods of direct suppression action. One or more of the following is usually involved: <ul style="list-style-type: none"> <li>(1) high rates of spread</li> <li>(2) prolific crowning and/or spotting</li> <li>(3) presence of fire whirls</li> <li>(4) a strong convection column</li> </ul> Predictability is difficult because such fires often exercise some degree of influence on their environment and behave erratically, sometimes dangerously.
Fine fuel	Fuels such as grass, leaves, and fine twigs that ignite readily and are burnt rapidly when dry. They are usually defined as less than 6 millimetres in thickness.
Fingers	Long and narrow slivers of fire which extend beyond the head or flanks.
Fire access road/track	A track constructed and/or maintained for fire management purposes, which is generally of a standard adequate for all-weather use by two-wheeldrive vehicles.
Fire behaviour	The manner in which a fire reacts to the variables of fuel, weather and topography. Common measures of fire behaviour are rate of spread, flame



	height, fire spotting distance and intensity
Fire break	Any natural or constructed discontinuity in a fuel bed that may be used to segregate, stop and control the spread of a fire, or to provide a fire control line from which to suppress a fire
Fire danger	(1) The resultant of all the factors, which determine whether fires start, spread and do damage, and whether and to what extent they can be controlled.  (2) An index which combines all the factors that determine the likelihood of a bushfire starting, spreading and causing damage to identified values, and the difficulty of control. Used for daily preparedness planning by land managers and on signs warning the public of the daily fire danger on a scale from low to extreme.
Fire Danger Index (FDI)	A relative number (1 to 100) denoting an evaluation of rate of spread or suppression difficulty for specific combinations of fuel, fuel moisture and wind speed.
Fire danger rating (FDR)	A relative phrase denoting an evaluation of rate of spread or suppression difficulty for specific combinations of fuel, fuel moisture and wind speed
Fire hazard	Any fuel which if ignited may be difficult to extinguish
Fire hazardous area	An area where the combination of vegetation, topography, weather and the threat of fire to life and property, create difficult and dangerous problems
Fire intensity (kW/m)	(1) The rate of energy release for a given unit of fire perimeter.  (2) The heat (kilowatts) released per metre of fire perimeter; classified as low (<500 kWm <sup>-1</sup> ), moderate (500–3000 kWm <sup>-1</sup> ), high (3000–7000 kWm <sup>-1</sup> ) or very high (7000–70 000 kWm <sup>-1</sup> ).
Fire risk	The probability of a fire starting
Fire run	A rapid advance of a fire front. It is characterised by a marked transition in intensity and rate of spread
Fire storm	Violent convection caused by a large continuous area of intense fire. Often characterised by destructively violent surface indrafts, a towering convection column, long distance spotting, and sometimes by tornado like whirlwinds
Flame angle	The angle of the flame in relation to the ground, caused by wind direction





	or the effect of a slope.
Flame height	The vertical distance between the tip of the flame and ground level, excluding higher flame flashes
Flammability	The ease with which a substance is set on fire
Forest	<p>(1) An area, incorporating all living and non-living components, that is dominated by trees with an existing or potential stand height exceeding 5 metres, and with existing or potential projective foliage cover of overstorey strata of at least 30 per cent. This definition includes Australia's diverse native forests and plantations, regardless of age.</p> <p>(2) Woody vegetation with a potential top height greater than five metres and with a crown cover projection greater than 10 per cent.</p>
Forest Fire Danger Index (FFDI)	The index related to the chances of a fire starting, its rate of spread, intensity and difficulty of suppression according to various combinations of temperature, relative humidity, wind speed and both long and short term drought effects in a forest. See also <i>Fire Danger Index</i> . Readings are normally taken at 3 pm.
Forward rate of spread	The linear rate of advance of the head fire, usually expressed in kilometres per hour or metres per second
Fuel	<p><i>Fire fuel.</i> Any material such as grass, leaf litter, twigs, bark, logs and live vegetation that can be ignited and sustain a fire. Measured in tonnes per hectare.</p> <p><i>Fuel type.</i> An association of fuel characteristics such as species, form, size, and arrangement that will cause a predictable rate of spread, or difficulty of suppression, under specified weather conditions.</p> <p>(1) <i>Heavy fuel.</i> Dead woody material in contact with the soil surface, greater than 25 millimetres in diameter. Also called 'coarse fuel'.</p> <p>(2) <i>Litter fuel.</i> The top layer of the forest floor composed of loose dead sticks, branches, twigs and recently fallen leaves little altered by decomposition.</p> <p>(3) <i>Surface fuel.</i> The loose surface litter on the forest floor. Can consist of fallen leaves, twigs, bark, small branches, grasses,</p>



	<p>shrubs, tree saplings less than a metre high, heavier branches, fallen logs, stumps, seedlings and small plants.</p> <p>(4) <i>Trash</i>. The component of surface fuel above the leaf litter layer made up of dead twigs, branches and scrub debris of at least 10 millimetres diameter.</p> <p>(5) <i>Fine fuel</i>. Dead leaves, twigs and bark in the litter layer less than 6 millimetres thick as well as the green leaves and twigs of shrubs and grasses less than 2 millimetres in diameter, and all less than 1 metre above the ground.</p> <p>(6) <i>Elevated fuel</i>. Fuels that are suspended above the ground, such as shrubs, bark, seedlings.</p> <p>(7) <i>Available fuel</i>. The amount or weight of fuel that will be consumed under prevailing weather conditions during a prescribed burn or a bushfire. Available fuel can be less than total fuel, where part of the fuel profile is still damp from previous rain. Measured in tonnes per hectare.</p> <p>(8) <i>Total fuel</i>. The sum of the fuel quantity of litter, trash, scrub and fuels that are available to burn under extreme wildfire conditions. Measured in tonnes per hectare.</p> <p>(9) <i>Fuel age</i>. The period of time elapsed since fuel was last burnt, usually expressed in years.</p> <p>(10) <i>Fuel load</i>. The oven-dry weight of fuel per unit area. Also known as fuel quantity. Expressed as tonnes per hectare.</p>
Fuel array	The totality of fuels displayed in a location: fine and coarse, live and dead
Fuel moisture content	The moisture content of fuel expressed as a percent of the oven dry weight of the fuel.
Fuel reduction burn	A prescribed burn carried out with the intention of reducing the fire fuel so as to minimise the intensity of any subsequent bushfire and to ensure the bushfire is easier and safer to suppress
Grassfire	An unplanned fire burning in predominantly grassy fuels.
Grassland curing	A proportion of dead material in grasslands—usually increases over summer as tillers die off and dry out, increasing the risk of grassland fire
Hazard	A source of potential harm, or a situation with a potential to cause loss



Head fire	The part of a fire where the rate of spread, flame height and intensity are greatest, usually when burning downwind and/or upslope
Ignitability	The ease with which a material ignites
Indirect attack	A fire suppression method where the fire is intended to be brought under control a considerable distance away from its current position, but within a defined area, bounded by existing or planned fire control lines. Backburning is a common method of achieving this
Keetch–Byram Drought Index (KBDI)	A numerical value reflecting the dryness of soils, deep forest litter, logs and living vegetation and expressed as a scale from 0 to 200.
Likelihood	Used as a qualitative description of probability or frequency
Litter	The top layer of the forest floor composed of loose debris of dead sticks, branches, twigs, and recently fallen leaves and needles
Low Threat Vegetation	Vegetation defined in AS3959:2009 section 2.2.3.2  <ol style="list-style-type: none"> <li>(1) Vegetation of any type that is more than 100 m from the site.</li> <li>(2) Single areas of vegetation less than 1 ha in area and not within 100 m of other areas of vegetation being classified.</li> <li>(3) Multiple areas of vegetation less than 0.25 ha in area and not within 20 m of the site, or each other.</li> <li>(4) Strips of vegetation less than 20 m in width (measured perpendicular to the elevation exposed to the strip of vegetation) regardless of length and not within 20 m of the site or each other, or other areas of vegetation being classified.</li> <li>(5) Non-vegetated areas, including waterways, roads, footpaths, buildings and rocky outcrops.</li> <li>(6) Low threat vegetation, including grassland managed in a minimal fuel condition, maintained lawns, golf courses, maintained public reserves and parklands, vineyards, orchards, cultivated gardens, commercial nurseries, nature strips and windbreaks.</li> </ol> <p>NOTE: Minimal fuel condition means there is insufficient fuel available to significantly increase the severity of the bushfire attack (recognizable as short-cropped grass for example, to a nominal height of 100 mm).</p>
Mild conditions	Conditions of weather and fuel such that if a fire starts it will behave mildly and can be easily suppressed. For example: <ol style="list-style-type: none"> <li>(1) wind—less than 15 kilometres per hour</li> <li>(2) temperature—less than 25°C</li> <li>(3) relative humidity—greater than 50 per cent</li> <li>(4) moisture content of fuel 2 to 20 per cent</li> <li>(5) tonnes per hectare of fuel—up to 8 tonnes per hectare.</li> </ol>



Mineral earth	A non-flammable soil surface, either natural or prepared.
Objective	A goal statement of what is to be achieved
Plantation	<p>A forest established by the planting of trees of either native or exotic species. Can also comprise dense plantings of commercial shrub species, for example oil mallees or tea tree plantations, or horticultural crops such as sugar cane.</p> <p>Any area of planted trees, other than a wind break, that exceeds three hectares in a gazetted town site or elsewhere a stand of trees 10 hectares or larger, that has been established by sowing or planting native or exotic tree species selected and managed intensively for their commercial and environmental value. A plantation includes roads, tracks, fire breaks and small areas of native vegetation.</p>
Preparedness	All activities undertaken at any time in advance of a wildfire occurrence to decrease wildfire area and severity and to ensure more effective suppression
Prescribed burn	The controlled application of fire to a defined area of land conducted in accordance with an approved burn plan to meet specified management objectives
Rate of spread (ROS)	<p>The rate at which a fire advances. It is measured in metres per hour. Mild fires used for prescribed burning in forests have rates of spread generally below 40 metres per hour.</p> <p>A bushfire spreads in four directions—the headfire (which burns downwind or with the wind behind it), the flank fires (which spread sideways) and the tailfire (where the back of the fire burns slowly into the wind). A fire is usually elliptical in shape, since the headfire rate of spread is always at least double the flankfire rate of spread. Intense bushfires can have a headfire rate of spread that exceeds 3000 metres an hour. The rate of spread depends mainly on wind strength, vegetation type, fuel quantity and slope.</p>
Relative humidity	The amount of water vapour in a given volume of air, expressed as a percentage of the maximum amount of water vapour the air can hold at that temperature



Residual risk	The remaining level of risk after risk treatment measures have been taken
Risk	The chance of something happening that will have an impact upon objectives. It is measured in terms of consequences and likelihood
Risk reduction	A selective application of appropriate techniques and management principles to reduce either likelihood of an occurrence, its consequences, or both
Scorch height	The maximum height above the ground to which the leaves of trees or shrubs are browned by a fire. Generally about four times the flame height. In Australia, eucalyptus tree crowns that are merely scorched by a fire tend to recover, whereas trees that are defoliated can take several years to recover or may never recover
Scrub	Vegetation, such as heath and shrubs, that grows either as an understorey or by itself in the absence of a tree canopy. The components of scrub are usually called shrubs. In coastal areas, scrub is often referred to as 'heath' or 'heathland'.
Spot fire	A new fire occurring downwind of a headfire (up to 10 kilometres has been observed), usually started by a piece of burning bark. Compare with 'hop over' which is a new fire that has started immediately across a fireline and not necessarily at the headfire
Spotting	Behaviour of a fire producing sparks or embers that are carried by the wind or convective activity and start new fires beyond the zone of direct ignition by the main fire
Structure fire	A fire burning part or all of any building, shelter or other construction
Surface fire	A fire that travels just above ground surface in grass, low shrub, leaves and litter
Topography	The nature of the land surface in terms of slope, steepness, aspect, elevation and landscape pattern. Terms such as mountainous, hilly, undulating, and flat describe the general topography
Total fire ban	Total fire ban (day); declared for days of very high fire risk in regions of the state; prohibits the lighting of any fires in the open air
Urban–rural interface	The line, area or zone where structures and other human development adjoin or overlap with undeveloped bushland
Water point	Any natural or constructed supply of water that is readily available for fire



	control operations
Woodland	Large tract of land covered by trees but more open than a forest and often with a grassy understorey.