

**AREAS:**

	PERIM. (m)	AREA (m <sup>2</sup> )
HOUSE	57.11	119.10
GARAGE	23.40	34.20
ALFRESCO	14.80	11.41
PORCH	5.16	1.66
		166.37 m <sup>2</sup>
<b>ROOF AREAS</b>		
ROOF AREA[m <sup>2</sup> ON THE FLAT]		160.11

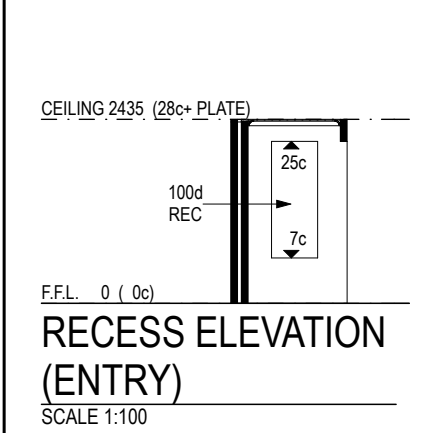

Sub-contractors to verify all dimensions on site.

REVISION	VO #	DRN	DATE	CHK

CLIENT:	DATE:

CLIENT: SURELAND DEVELOPMENTS  
 ADDRESS: LOT 612, 613, 614, 621  
 659 & 665 TUFTS LANE  
 AUBIN GROVE

CLIENT: SURELAND DEVELOPMENTS  
 ADDRESS: LOT 612, 613, 614, 621  
 659 & 665 TUFTS LANE  
 AUBIN GROVE

MODEL N°	DATE

ONE-OFF  
 2c BLOCKS  
 SHEET N° 1 OF 6

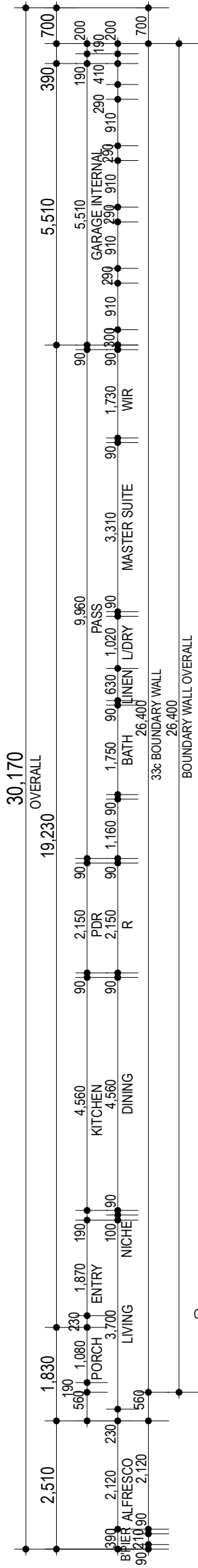

**FLOOR PLAN**  
 SCALE 1:100

230 CAVITY BRICKWORK  
 THIRD BOND FINISH  
 EXTERNALLY, ACRYLIC  
 RENDER FINISH WHERE  
 SHOWN ON ELEVATIONS.

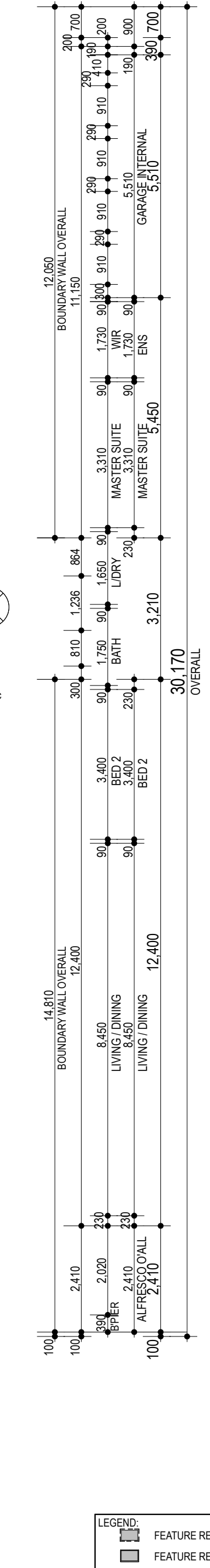
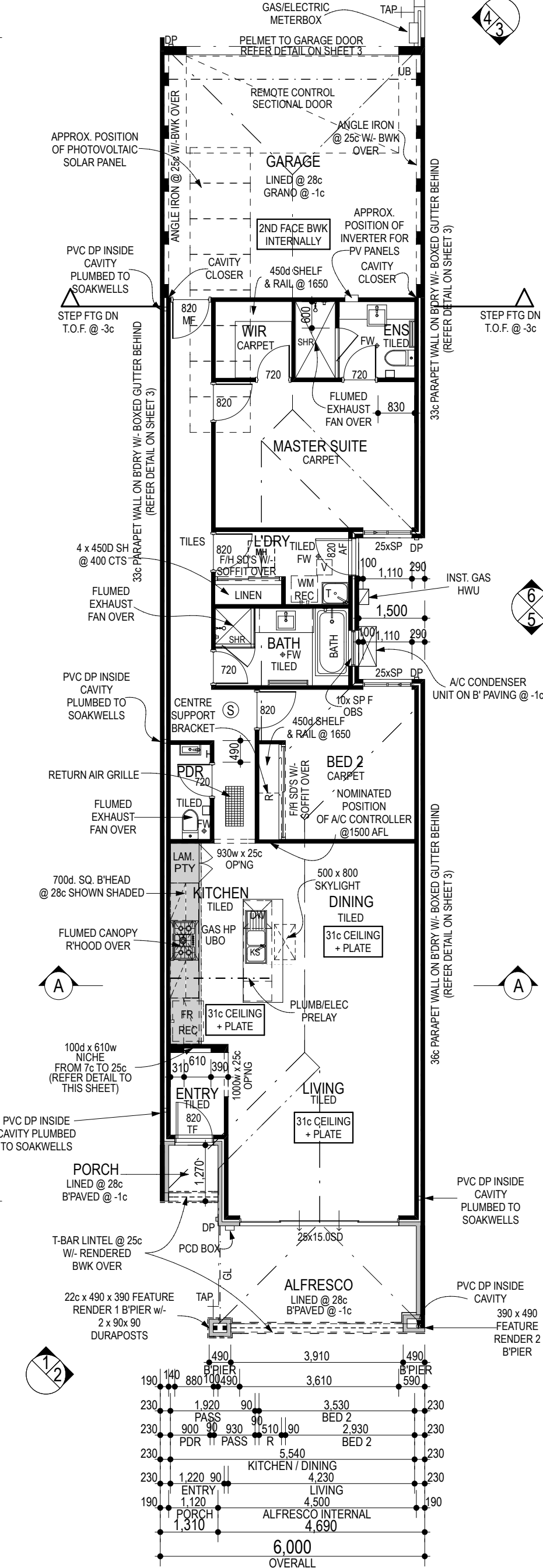

**NOTE:**

- R4.0 INSULATION TO CEILING AREAS OF HOUSE AND GARAGE ONLY.
- LOCATION OF DOWNPIPES ARE INDICATIVE ONLY AND MAY BE REPOSITIONED AT BUILDER'S DISCRETION.
- 28c CEILING + PLATE THROUGHOUT HOUSE UNLESS NOTED OTHERWISE.
- FLOOR WASTE TO WET AREAS ARE INDICATIVE ONLY.

**LEGEND:**

	FEATURE RENDER 1
	FEATURE RENDER 2

**LEGEND:**

[Grey Box]	MAIN RENDER:
[Dark Grey Box]	FEATURE RENDER 1
[Light Grey Box]	FEATURE RENDER 2:

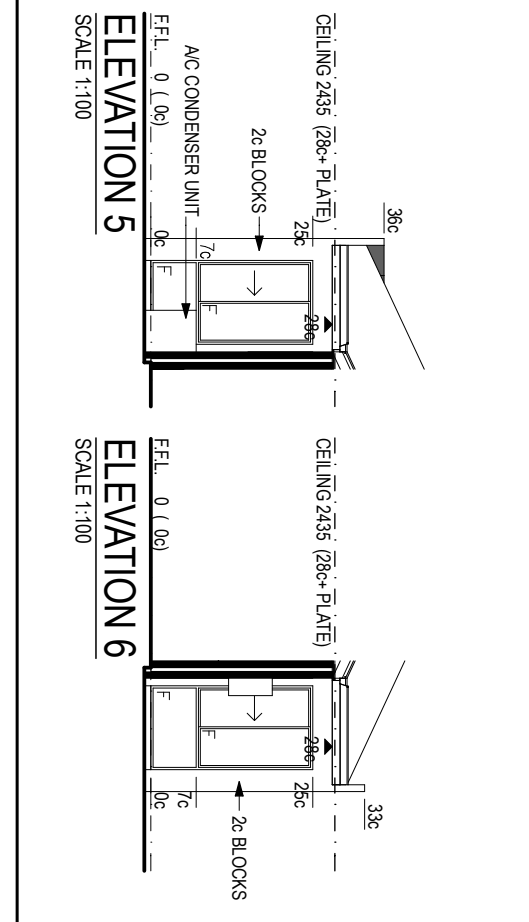
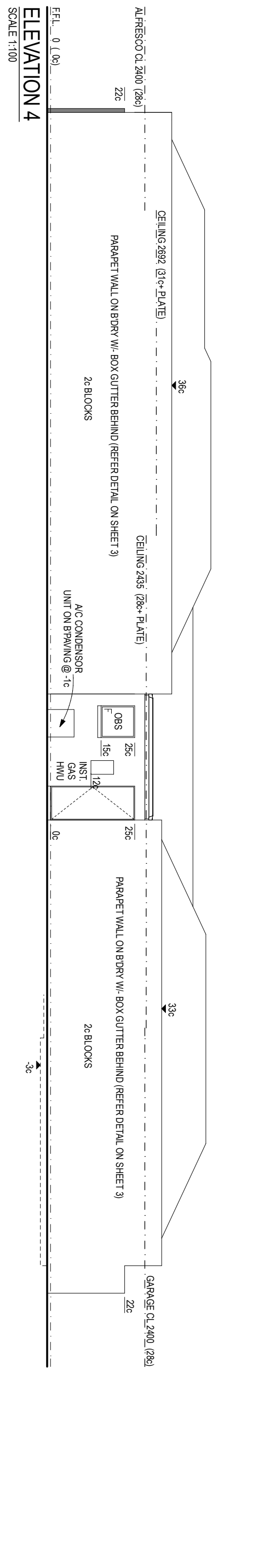
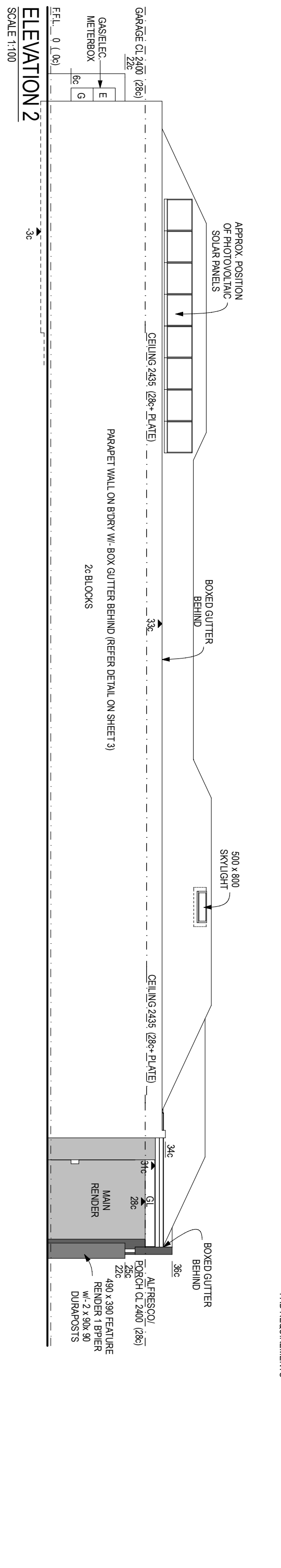
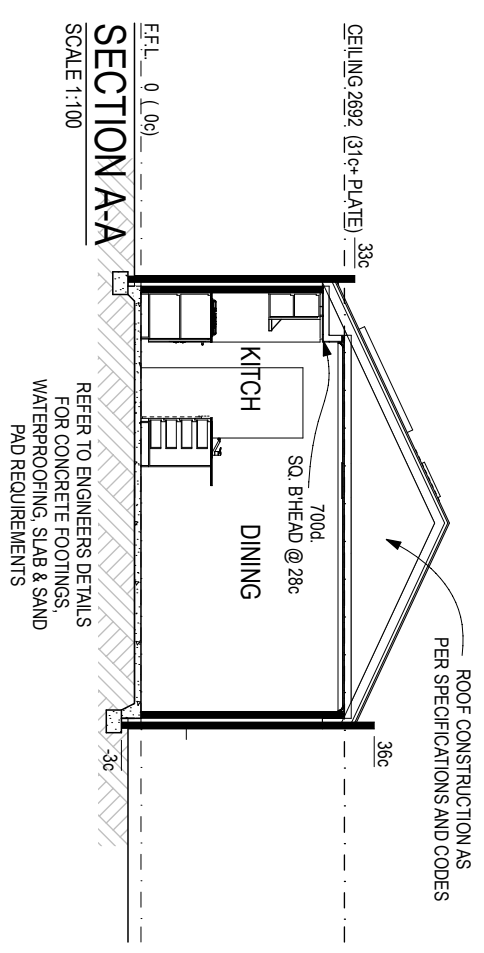
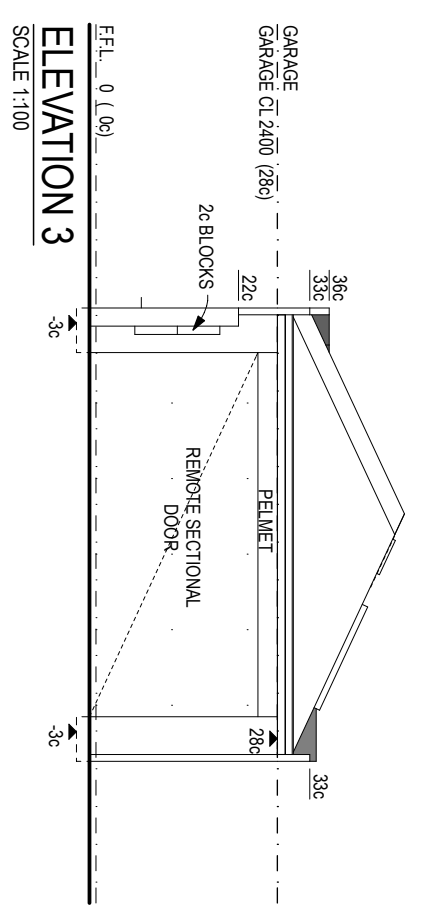
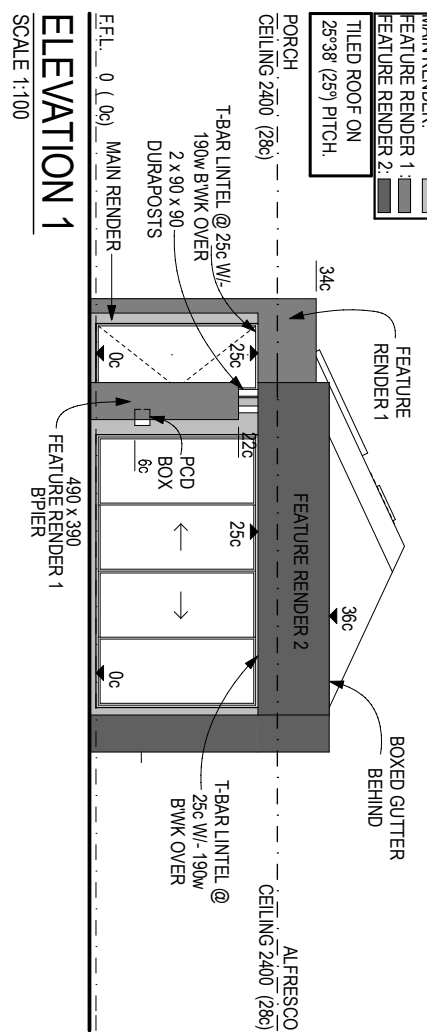

**FINAL PLANS**

© COPYRIGHT

**ONE-OFF**

2c BLOCKS

REVISION	VO #	DRN	DATE	CHK

CLIENT:	DATE:
CLIENT:	DATE:
CLIENT:	DATE:
CLIENT:	DATE:

Sub-contractors to verify all dimensions on site.

ORIGINAL

CLIENT:	MODEL N°
SURELAND DEVELOPMENTS	DATE
ADDRESS:	MAP REF
LOT 612, 613, 614, 621	WIND RATING
659 & 665 TUFTS LANE	COASTAL CATEGORY
AUBIN GROVE	ENGINEERS DETAIL
JOB N°	SHEET N°
	2 OF 6

DOCN031665 SKETCH DRAWINGS

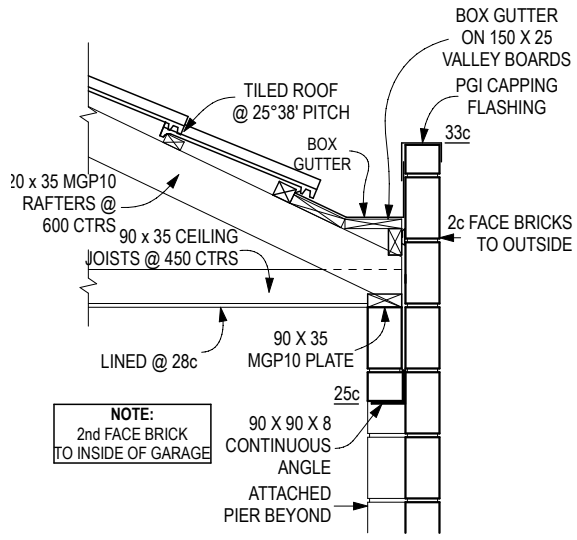

**PARAPET WALL DETAIL W/-  
TILED ROOF (GARAGE)**

SCALE 1: 20

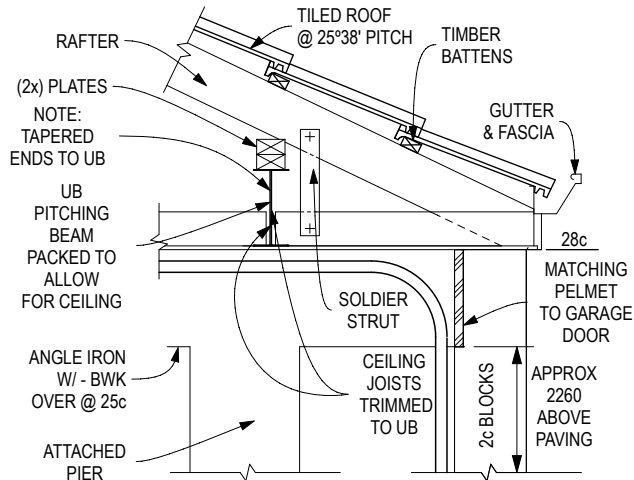

**GARAGE DOOR DETAIL**

SCALE 1: 20

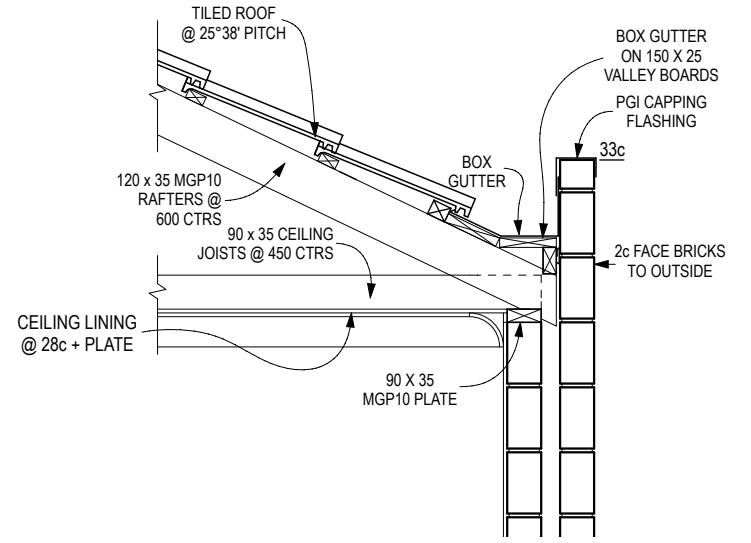

**PARAPET WALL DETAIL W/- TILED ROOF  
(ENS & MASTER SUITE)**

SCALE 1: 20

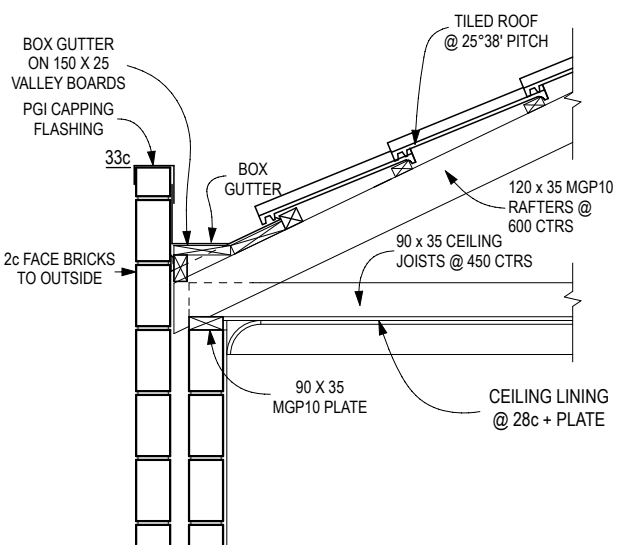

**PARAPET WALL DETAIL W/-  
TILED ROOF (PDR, PASS & ENTRY)**

SCALE 1: 20

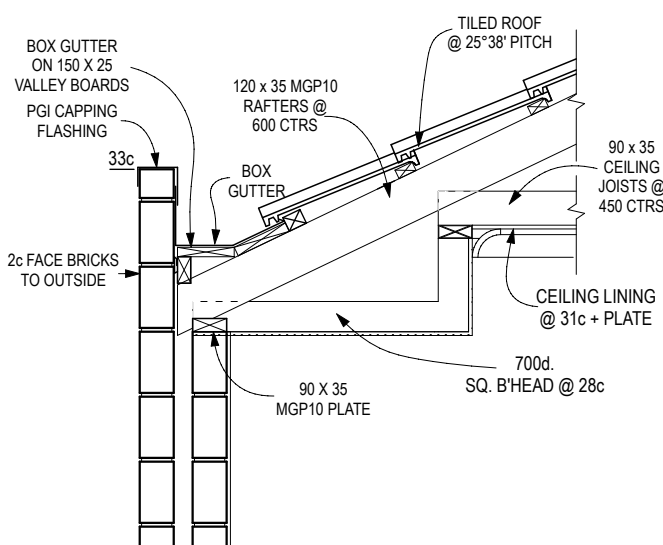

**PARAPET WALL DETAIL W/-  
TILED ROOF (KITCHEN)**

SCALE 1: 20

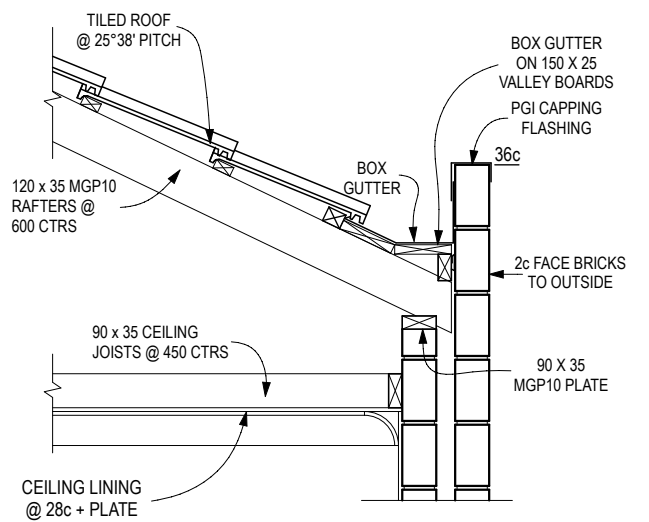

**PARAPET WALL DETAIL W/-  
TILED ROOF (BED 2)**

SCALE 1: 20

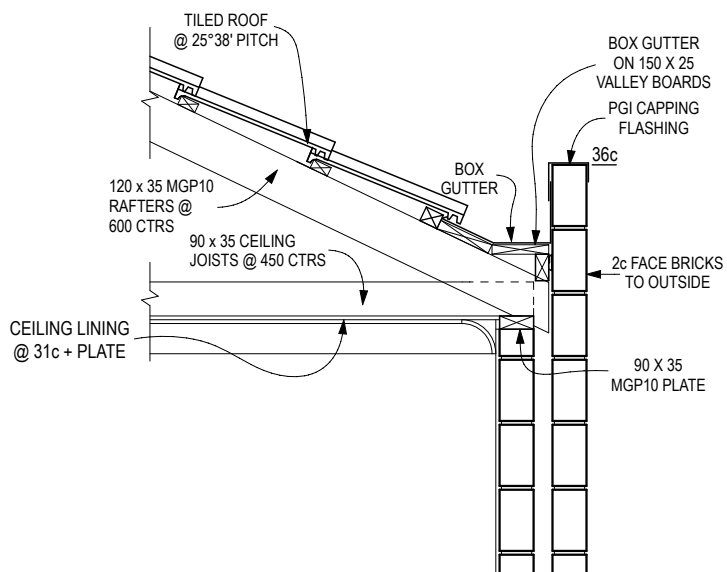

**PARAPET WALL DETAIL W/-  
TILED ROOF (DINING/LIVING)**

SCALE 1: 20

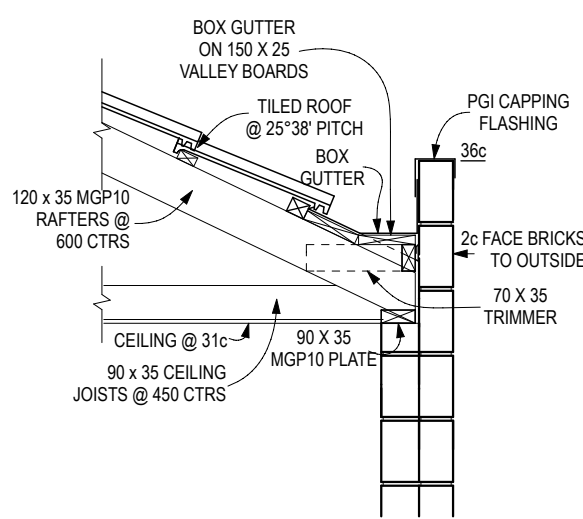

**PARAPET WALL DETAIL W/-  
TILED ROOF (ALFRESCO)**

SCALE 1: 20

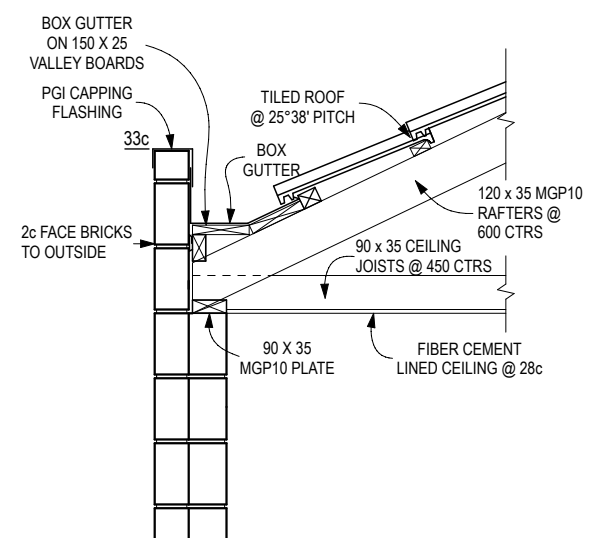

**PARAPET WALL DETAIL W/-  
TILED ROOF (PORCH)**

SCALE 1: 20

**FINAL PLANS**

REVISION	VO #	DRN	DATE	CHK	CLIENT:	CLIENT:	NEW DREAM LIVING SPECS.	2c BLOCKS
		AO	RE	RE				
					DATE:	SURELAND DEVELOPMENTS	MODEL N°	DATE
					CLIENT:	ADDRESS:	MAP REF.	WIND RATING
					DATE:	LOT 612, 613, 614, 621	COASTAL CATEGORY	ENGINEERS DETAIL
					BUILDER:	659 & 665 TUFTS LANE	JOB N°	SHEET N°
					DATE:	AUBIN GROVE		3 OF 6
Sub-contractors to verify all dimensions on site.								

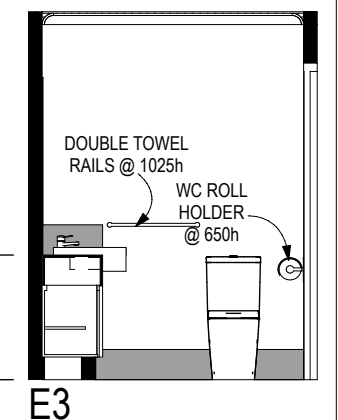
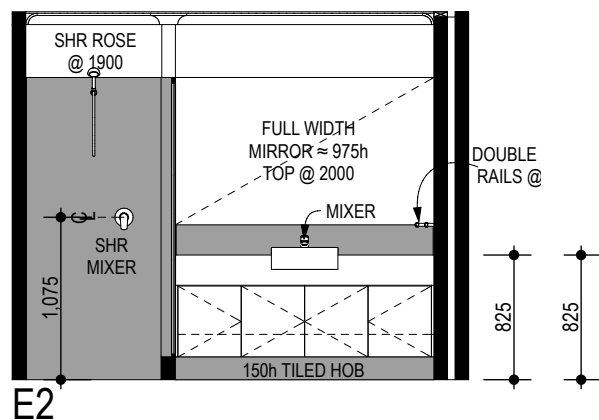
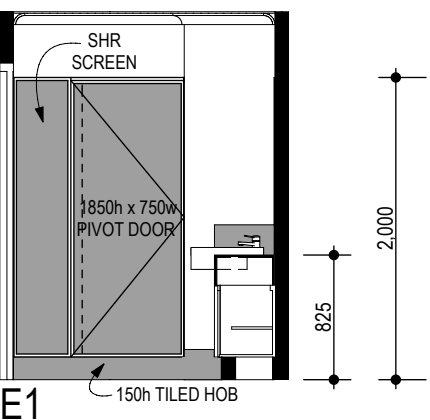
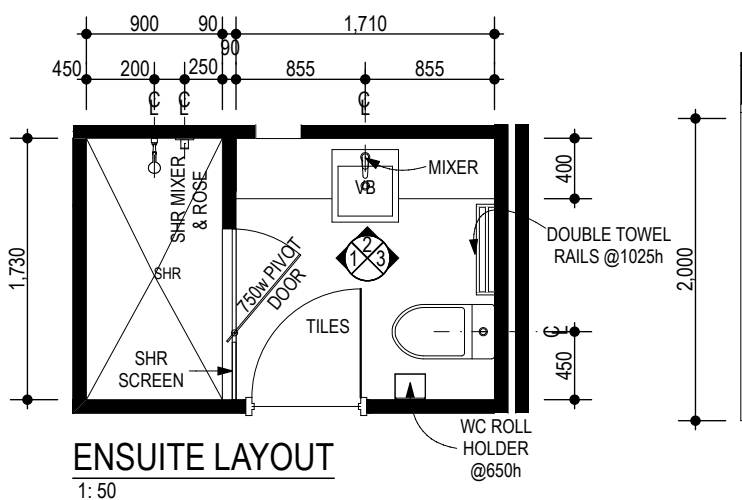
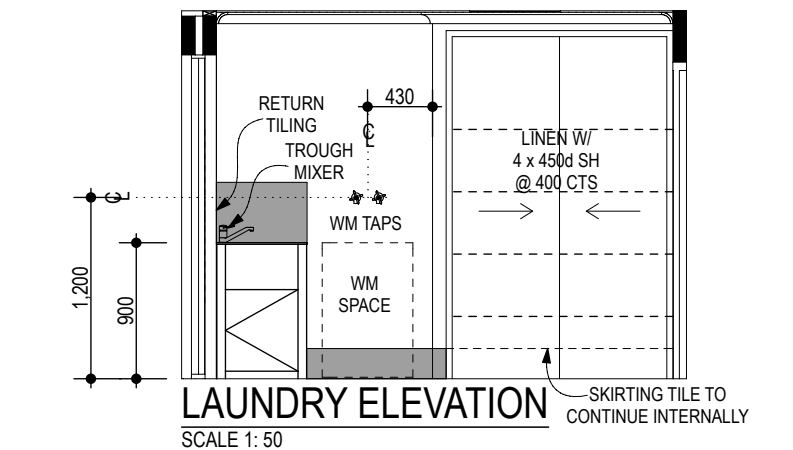
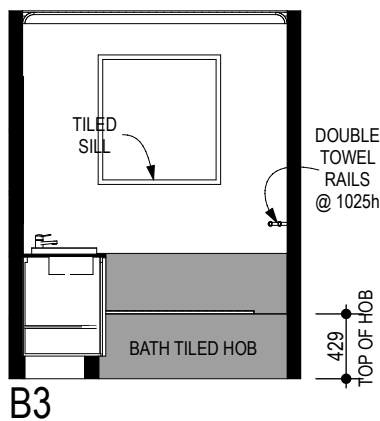
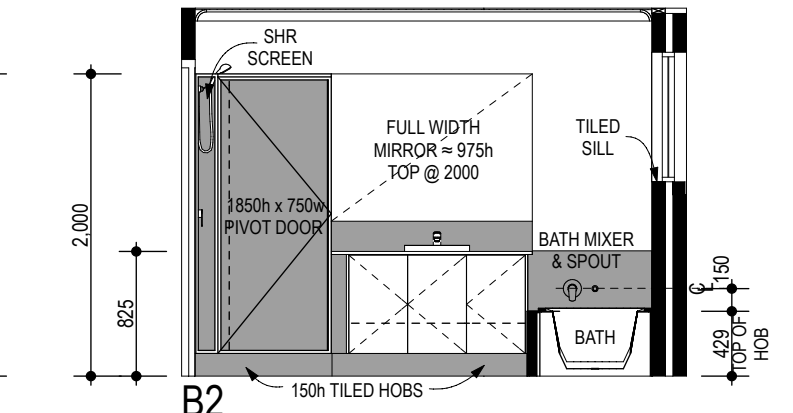
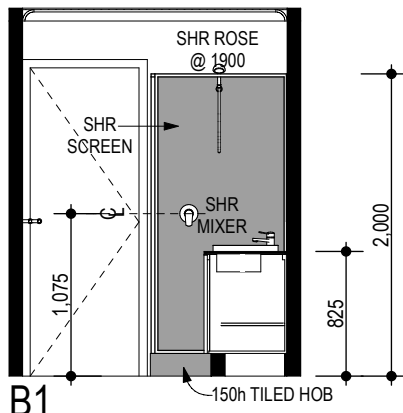
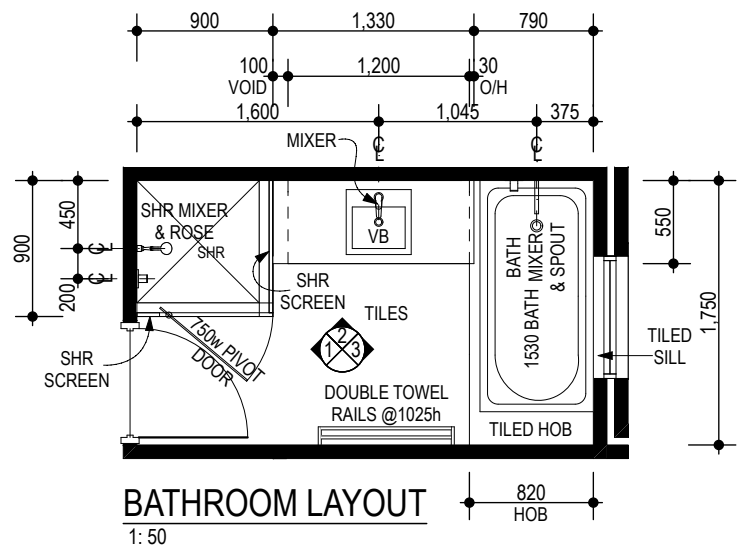
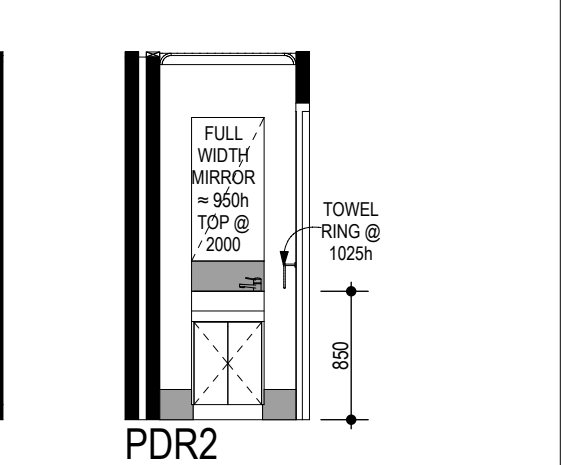
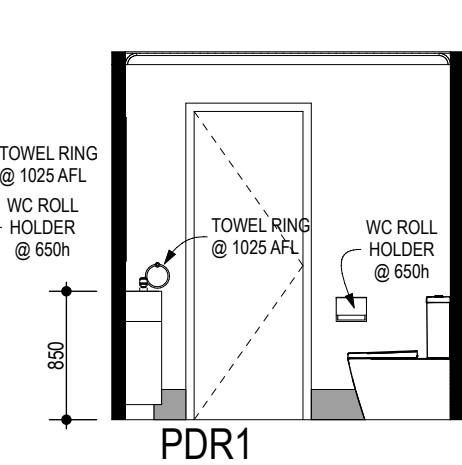
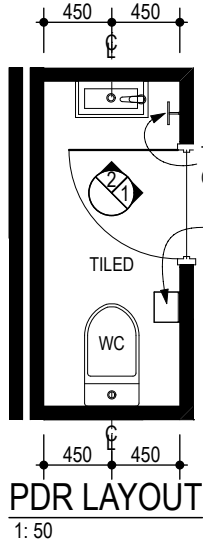
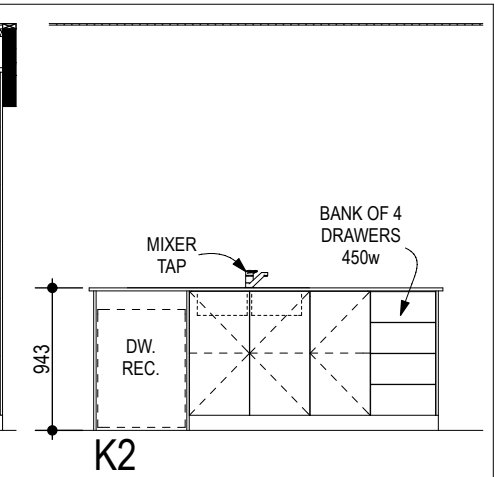
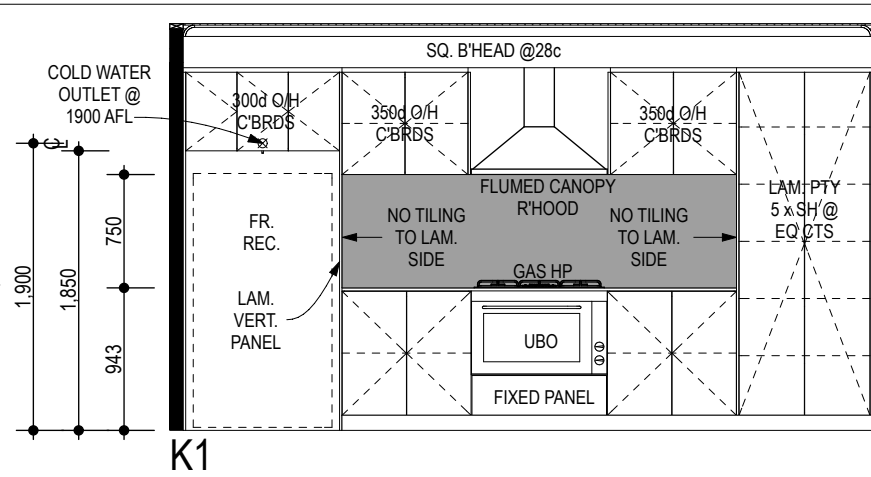
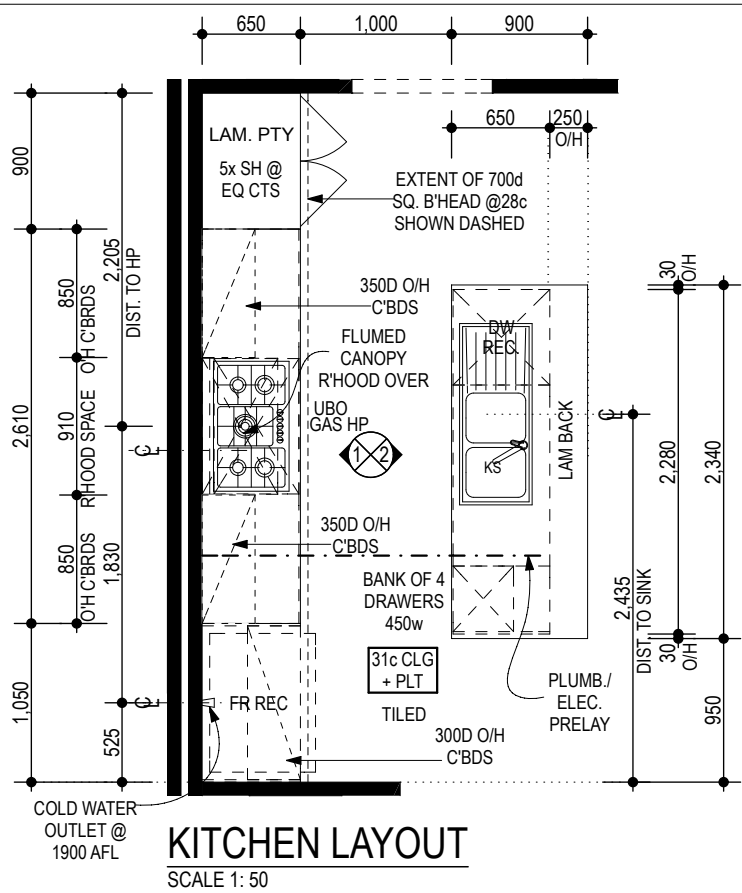

**NOTE:**  
LOCATION OF BENCHTOP JOINS ARE AT THE DISCRETION OF THE CABINET MAKER.

**NOTE:**  
THE APPEARANCE OF FIXTURES & FITTINGS IN THE DRAWINGS ARE DIAGRAMMATIC ONLY.

**NOTE:**  
DETAILS OF CABINETS ARE INDICATIVE ONLY. THE DIMENSIONS ON PLAN EXCLUDES PLASTER WORK, END PANELS & SCRIBE FILLETS. THE LOCATION OF THE KITCHEN SINK, SIZE OF THE CABINET DOORS AND DRAWERS MAY VARY FROM THOSE SHOWN ON PLAN, INCLUDING DIMENSIONED DETAILS.

**NOTE:**  
CLIENT TO MEET TILER ON SITE TO CONFIRM LAYING OF WALL AND FLOOR TILES PRIOR TO COMMENCEMENT. INCLUDING BORDER TILES IN CONJUNCTION WITH TILE SELECTION. EXTENT OF TILES SHOWN SHADED ON ELEVATIONS.

IT IS THE CONTRACTOR'S RESPONSIBILITY TO CHECK & CONFIRM CURRENT PRODUCT CUT-OUT SIZES.

APPLIANCES			
	UBO (FLUSH)	GAS HP	R/HOOD (FLUMED)
MAKE			
MODEL			
FINISH		STAINLESS STEEL	STAINLESS STEEL
CUT-OUT	H		
	W		
	D		

**DISHWASHER PROVISION:**

- 610w OPENING UNDER BENCH TOP.
- COLD WATER OUTLET @ 300 A.F.L.
- SINK TRAP SUITABLE TO CONNECT DISHWASHER WASTE.
- SUPPLY S.G.P.O. @ 300 A.F.L.
- CABINETWORK CUTOUT FOR SERVICES BY DISHWASHER INSTALLER.

REVISION	VO #	DRN	DATE	CHK
		AO		RE

CLIENT: .....

DATE: .....

CLIENT: .....

DATE: .....

BUILDER: .....

DATE: .....

Sub-contractors to verify all dimensions on site.

CLIENT:  
**SURELAND DEVELOPMENTS**

ADDRESS:  
**LOT 612, 613, 614, 621  
659 & 665 TUFTS LANE  
AUBIN GROVE**

© COPYRIGHT

**ONE-OFF**

2c BLOCKS

MODEL N°	DATE
MAP REF.	WIND RATING
COASTAL CATEGORY	ENGINEERS DETAIL
JOB N°	SHEET N° <b>4 OF 6</b>

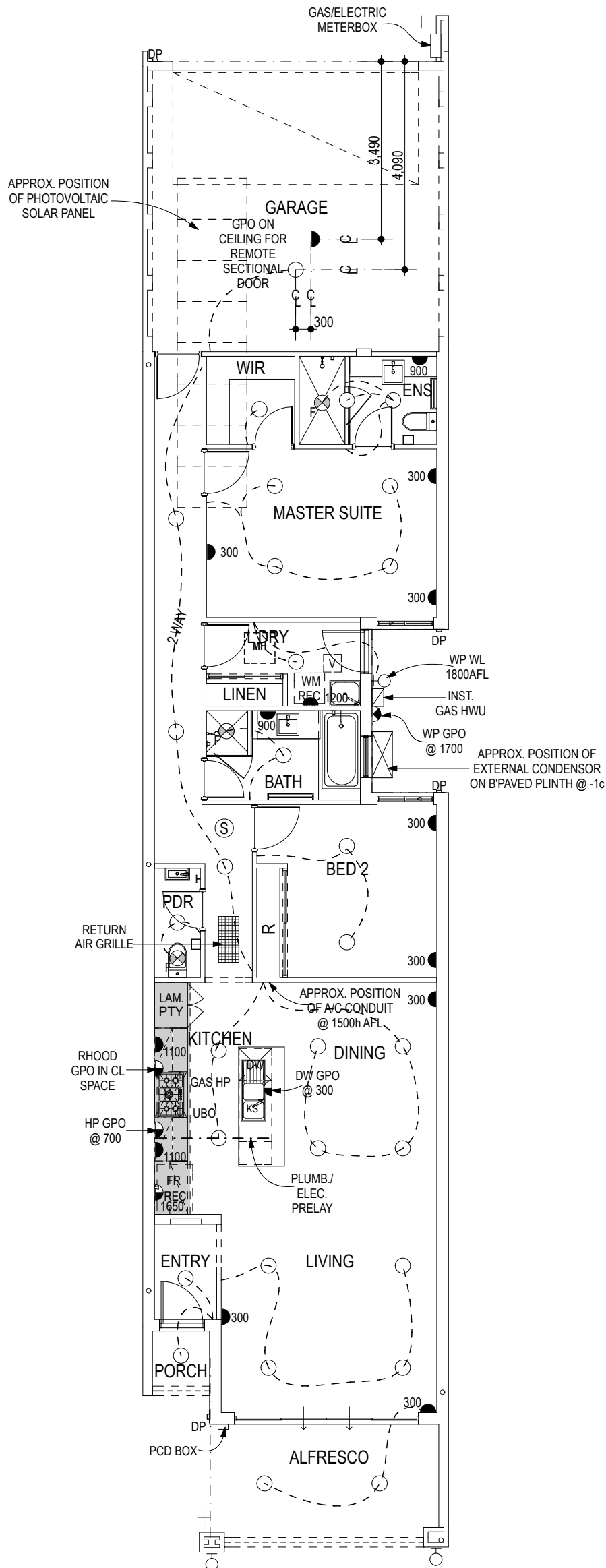

**ELECTRICAL PLAN**  
SCALE 1:100

ELECTRICAL LEGEND		
DOWN LIGHT	○	29
DOUBLE GPO	◐	13
SINGLE GPO	◑	4
FLUMED EXHAUST FAN	⊗	3
WALL LIGHT @ 1800 AFL	○-I	3
H.WIRED SMOKE DETECTOR	Ⓢ	1
SINGLE GPO @ 300 AFL	◑	1
CEILING LIGHT (15w)	○	1
2 WAY SWITCH	2 WAY	1
DOUBLE WATER PROOF GPO	◑	1
OUTDOOR AIR CONDITIONING ROOF UNIT	⊠	1
Air Conditioning Return Air Grill	⊞	1

**NOTE:**

- ELECTRICAL TO BE DONE AS PER JOB NO. 89757, TO BE CONFIRMED AT PRESTART.
- PROVIDE ESSENTIAL LIVING PACKAGE READY STAGE ONLY.
- PROVIDE DUCTED AIR CONDITIONER AS PER BUILDERS STANDARD.

REVISION	VO #	DRN	DATE	CHK	CLIENT: .....	CLIENT: SURELAND DEVELOPMENTS	ADDRESS: LOT 612, 613, 614, 621 659 & 665 TUFTS LANE AUBIN GROVE	ONE-OFF	
		AO	RE	RE				NEW DREAM LIVING SPECS.	2c BLOCKS
					DATE: .....			MODEL N°	DATE
					CLIENT: .....			MAP REF.	WIND RATING
					DATE: .....			COASTAL CATEGORY	ENGINEERS DETAIL
					BUILDER: .....			JOB N°	SHEET N°
					DATE: .....				5 OF 6

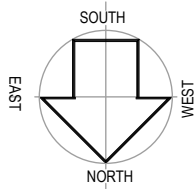

**WARNING!**  
BOUNDARY RE-PEG SURVEY  
REQUIRED TO CONFIRM PEG POSITIONS

**LOTS 657**  
SANDY

NOTE: APPROXIMATELY 8.4 Km  
FROM COAST LINE

NOTE: A.H.D. VALUE DERIVED FROM  
SEWER MANHOLE AB9492. THIS VALUE  
DERIVED FROM WATER CORP. AS  
CONSTRUCTED RECORDS & MAY NOT BE  
EXACT. AN A.H.D. SURVEY IS REQUIRED  
TO OBTAIN AN ACCURATE VALUE.

**NOTE: BOUNDARY POSITION  
AS PER ALIGNMENT  
REQUIRES REPEG SURVEY**

NOTE:  
STORMWATER DISPOSAL TO COUNCIL  
REQUIREMENTS, SOAKWELLS WHERE  
SHOWN TO HAVE TRAFFICABLE LIDS.

NOTE:  
NO BUILT UP SAND PAD REQUIRED  
STRUCTURALLY.

NOTE:  
THE OWNER IS LIABLE FOR  
REMOVAL OF ANY BOUNDARY FENCES  
IF REQUIRED FOR  
CONSTRUCTION PURPOSES

230 CAVITY  
BRICKWORK THIRD  
BOND FINISH EXTERNALLY  
& ACRYLIC RENDER AS  
SHOWN ON ELEVATION

RCODE REQUIREMENTS R60	REQUIRED	COMPLIES
FRONT SETBACK	3m (MIN)	YES
OPEN SPACE	60%	YES
B'DARY WALL LENGTH	75% BEHIND SETBACK	YES
BOUNDARY WALL BEHIND SETBACK LINE		YES
OVERLOOKING CONES OF VISION SHOWN		N/A

**SITE PLAN**  
SCALE 1:200

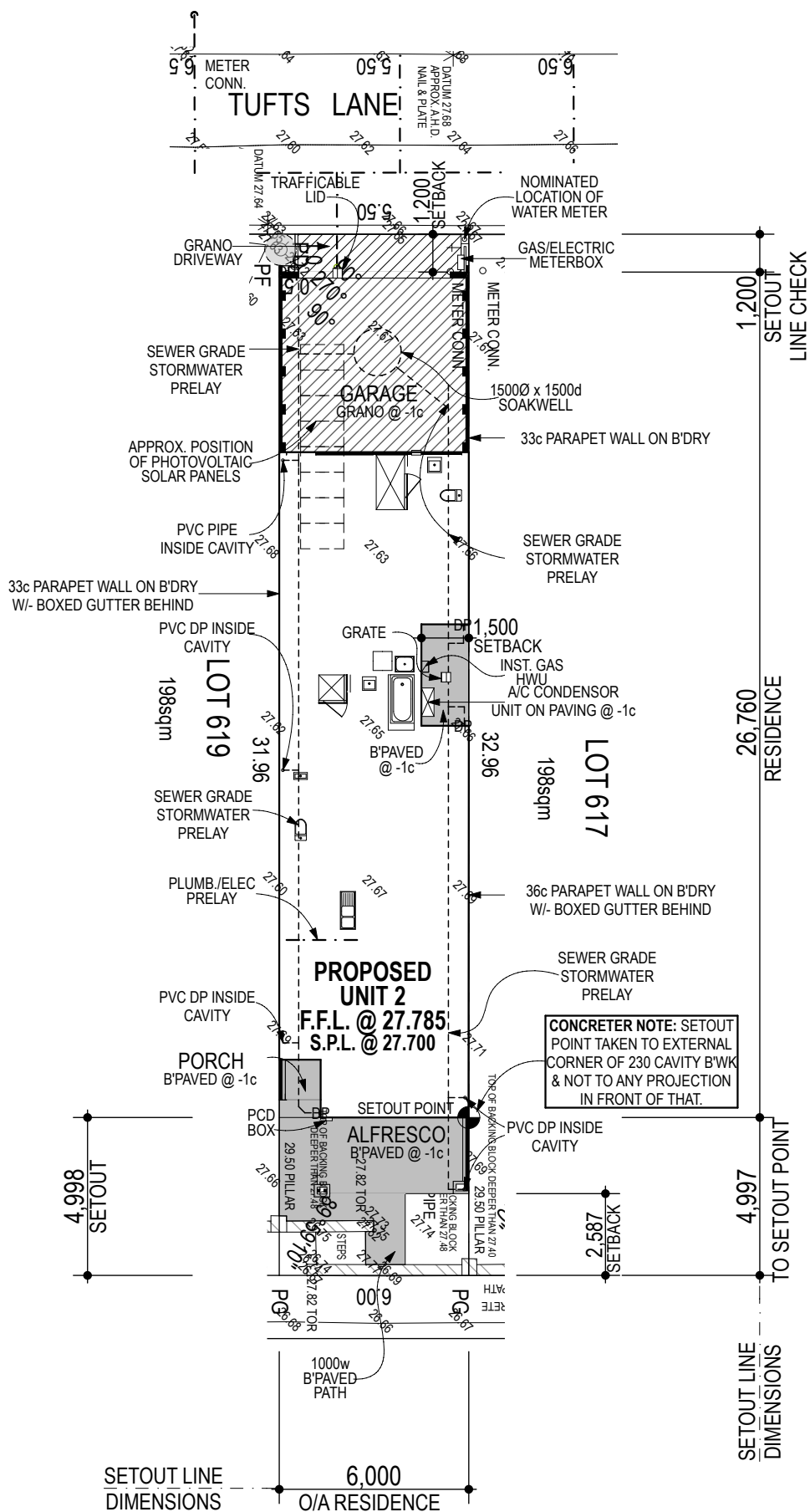

CLIENT: .....  
DATE: .....  
CLIENT: .....  
DATE: .....  
BUILDER: .....  
DATE: .....

JOB N° ..... SHEET N° **6 OF 6**

REVISION	VO #	DRN	DATE	CHK
		AO		RE

Sub-contractors to verify all dimensions on site.  
DOCNO:91665:SKETCH:DRAWINGS

PAVING / GRANO SCHEDULE			
	ID	TOP SURFACE [m2]	PERIMETER [m]
Floor Finish - B'Paving	Porch	1.42	4.78
Floor Finish - B'Paving	Drying	4.82	9.42
Floor Finish - B'Paving	Path	8.85	19.54
Floor Finish - B'Paving	Alfresco	11.03	14.20
		26.12 m <sup>2</sup>	47.94 m
Floor Finish - Grano	Driveway	7.12	13.12
Floor Finish - Grano	Garage	31.78	24.26
		38.90 m <sup>2</sup>	37.38 m

LOT 657  
SEW CONN POSITION  
APPROXIMATE ONLY  
SEW INV. 25.45  
UP. 1.90  
DEPTH. 0.30m

CLIENT SURELAND	BUILDER	SCALE BAR	DRAFTED E.B.	SURVEYOR S.C.
LOT	AUTHORITY COCKBURN	SERVICE INFORMATION		
SUBURB AUBIN GROVE	MAP REF. 388 26 03	GAS BTC	SEWERAGE YES	DEPTH N/A
PLAN DP 408370	C/T Vol.Fol.	AREA NEW	WATER YES	PRELAI D YES N/A
DATE OF SURVEY	SCALE 1:200 @ A1	TELSTRA YES	POWER U/G	
JOB No. OURS:	YOURS:	WATER SV STOP VALVE	HY HYDRANT	FP FLUSH POINT
		METER WATER METER		
		SEWERAGE SEW SEWER MANHOLE	IS INSPECTION SHAFT	IQ INSPECTION OPENING
		GAS GAS	GAS METER	
		POWER CP CONSUMER POLE	PP POWER POLE	LP LAMP POST
		SP STAY POLE	PD POWER DOME	
		STORMWATER SW MANHOLE	GRATE	SIDE ENTRY PIT
		TELSTRA	TELSTRA PIT	
		SURVEY PF PEG FOUND	Pdist PEG DISTURBED	PG PEG GONE
		STATION	DATUM / CONTROL	

